

K0862-1

CROWN

SERVICE MANUAL

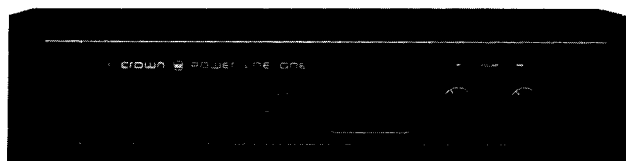

POWER LINE ONE
POWER AMPLIFIER

The information furnished in this manual does not include all of the details of design, production, or variations of the equipment. It does not cover all the possible contingencies which may arise during operation, installation, or maintenance. Should special problems arise, or further information be desired, please contact the Crown International Customer Services Department.

Crown International
1718 W. Mishawaka Rd.
Elkhart, Indiana 46514
Ph: (219) 294-5571

WARNING
TO PREVENT SHOCK OR
FIRE HAZARD DO NOT
EXPOSE TO RAIN OR
MOISTURE!



TABLE OF CONTENTS

RVW Sec. Review

I. Introduction	R-1
II. Warranty	R-1
III. Specifications	R-1
IV. Panel Configuration	R-3
V. Performance Graphs	R-4

Section 6 Illustrated Parts List

6.1 General Information	6-1
6.2 Standard and Special Parts	6-1
6.3 Ordering Parts	6-1
6.4 Shipment	6-1
6.5 Terms	6-1
6.6 Schematics/Parts Lists/Exploded View Drawings	6-3

Section 7 Maintenance

7.1 Introduction	7-1
7.2 Required Test Equipment	7-1
7.3 Soldering Techniques	7-2
7.4 Basic Troubleshooting	7-7
7.5 Disassembly for Inspection, Service, Testing, Adjustment and Repairs	7-8
7.6 Reassembly	7-10
7.7 Electrical Checkout and Adjustment Procedures	7-10
7.8 Troubleshooting Chart	7-13
7.9 Principles of Operation	7-15
7.10 Block Diagram Circuit Theory	7-16
7.11 Theory of Operation	7-17
7.12 Voltage Conversion	7-20

Section 8 Service Bulletins

8-1

LIST OF ILLUSTRATIONS

Fig. RVW.1	PL-1 Front Panel	R-3
Fig. RVW.2	PL-1 Rear Panel	R-3
Fig. RVW.3	Damping Factor	R-4
Fig. RVW.4	Output Impedance	R-4
Fig. RVW.5	Frequency Response; 1 watt 8 ohms	R-5
Fig. 6.1	PL-1 Power Supply Schematic	6-3
Fig. 6.2	PL-1 Main Schematic	6-3
Fig. 6.3	Main Foil Board Layout	6-4
Fig. 6.4	Main Foil Board Layout	6-4
Fig. 6.5	Display Component Board Layout	6-7
Fig. 6.6	Display Foil Board Layout	6-7
Fig. 6.7	Back Panel Assembly	6-8
Fig. 6.8	Front Panel Assembly	6-10
Fig. 6.9	Heatsink Assembly	6-11
Fig. 6.10	Final Assembly	6-12
Fig. 7.1	Miniature Soldering Iron	7-2
Fig. 7.2	Correct and Incorrect Solder Application	7-3
Fig. 7.3	Unsoldered Wire	7-3
Fig. 7.4	External Strands	7-4
Fig. 7.5	Cut Strands	7-4
Fig. 7.6	Wire Strippers	7-4
Fig. 7.7	Disturbed Joint	7-5
Fig. 7.8	Cold Solder Joint	7-6
Fig. 7.9	Rosin Joint	7-6
Fig. 7.10	Component Lead Spacing	7-6
Fig. 7.11	Component Lead Bending	7-6
Fig. 7.12	Correct Pressure Applied	7-6
Fig. 7.13	Acceptable Solder Joints	7-6
Fig. 7.14	Soldering to a Lug	7-7
Fig. 7.15	Turret Terminal	7-7
Fig. 7.16	Wire Braid Desoldering	7-7
Fig. 7.17	Offset Screwdriver	7-9
Fig. 7.18	LED Removal	7-9
Fig. 7.19	Cyanacrolete Application	7-9
Fig. 7.20	Cathode Lead of LED	7-9
Fig. 7.21	PL-1 Output Waveform (2 ohm)	7-11
Fig. 7.22	IM Distortion Test Set-up	7-12
Fig. 7.23	Signal to Noise Test Set-up	7-12
Fig. 7.24	PL-1 Block Diagram	7-16
Fig. 7.25	Input Operational Amplifier Stage	7-17
Fig. 7.26	Signal Translator Stage	7-17
Fig. 7.27	Final Voltage Amplifier Stage	7-18
Fig. 7.28	Bias, Output and Protection Stages	7-18
Fig. 7.29	IOC Indicator Stage	7-19
Fig. 7.30	Display Stage	7-19
Fig. 7.31	Low Frequency Protect/Mute Stages	7-20
Fig. 7.32	Voltage Conversion	7-20
Fig. 7.33	World-Wide Voltage Map	7-21

REVIEW SECTION

I. Introduction

This manual contains complete service information on the PL-1. It is designed to be used in conjunction with the PL-1 Instruction Manual. However, some important information is duplicated in this Service Manual in case the Instruction Manual is not readily available.

NOTE: THE INFORMATION IN THIS MANUAL IS INTENDED FOR USE BY AN EXPERIENCED TECHNICIAN ONLY!

II. Warranty

As a Crown Warranty Service Station, you should be familiar with Crown warranty policies. Each Instruction Manual contains basic policies as related to the customer. However, under questionable circumstances, please contact the Technical Service Department or Director of Customer Service at: Crown International, Inc., 1718 W. Mishawaka Road, Elkhart, IN 46514.

III. Specifications

General Specifications

Hum and Noise: From 20Hz to 20KHz the hum and noise level is below 65 microvolts (110dB below the rated output).

115dB below rated output A weighted.

Phase Response: +10°, -15°, 20Hz to 20KHz at 1 watt.

Input Impedance (RCA pin jacks, unbalanced): 25,000 ohms, actual; for use with low or high impedance sources.

Amplifier Output Protection: Total protection against shorted, mismatched or open outputs. IOC circuitry turns OFF the post-relay SPEAKER outputs whenever a considerable overload condition or DC output to the speakers exists continuously for more than 7 seconds; automatic reset of IOC timer prevents cumulative effect.

Overall Protection: AC line fused. Controlled slewing rate of voltage amplifiers protects against RF burnout. Input overload protection is furnished by an internal resistance at the amplifier's inputs. Thermal sensor turns OFF AC supply if temperature reaches 165° F.

DC Output Offset: (shorted input) ±10 millivolts.

Turn On: MAIN OUTPUT; instantaneous, with minimum thump and no program delay. SPEAKER OUTPUTS #1 & #2; 7-second turn-ON delay via relay and solid state timer.

AC Mains Requirements: Power supply may be restrapped to any of 5 nominal line voltages: 100, 120, 200, 220, or 240 volts AC (±10%); line frequencies of 50Hz, 60Hz or 400Hz.

Power Consumption: 30 watts at idle, 275 watts at full rated output.

Main Fuses: Two connected in series; 3 and 5 amps for 100 or 120v mains or 1.5 and 2.5 amps for 200, 220 and 240v mains.

Controls: POWER On/Off switch, SPEAKER 1 & 2 ON/OFF switches, Left and Right VOLUME controls, MONO mode switch on rear panel.

Indicators: One POWER ON indicator (amber LED). Left and Right IOC indicators (red LED's) turn ON whenever output signal waveform does not exactly match the input signal waveform (i.e., when there is clipping, excessive DC offset, or amplifier discharge on turn-off).

Left and Right channel "light sticks" (9 green and 3 amber LED's each) indicate peak relative voltage output top (amber) LED lights at rated power output.

Connectors: INPUT, 2 RCA-type pin jacks (phono jacks).

SPEAKER OUTPUT #1 & #2, dual color-coded quick connect binding posts for two pairs of stereo speaker systems.

Circuitry: All solid state, discrete transistors and diodes plus integrated circuits.

Construction: Rack mountable, machined front panel with anodized finish; nickel-plated chassis parts; handles included.

Heat Sinking: In addition to large rear-panel heat sinks for output devices, the entire amplifier (chassis, covers, and front panel) dissipates heat.

Dimensions: 3 1/2" high x 19" wide rack-mountable front panel, 10 3/4" from face of rack to maximum depth. (8.89cm H x 48.26cm W x 27.30cm D)

Net Weight: 15 pounds (6.82kg).

Stereo Specifications

Output Power (8 ohms): 50 watts minimum RMS into an 8 ohm load over a bandwidth of 20Hz-20KHz at a rated RMS sum total harmonic distortion of 0.05% of the fundamental output voltage, both channels operating.

Output Power (4 ohms): 80 watts minimum RMS into an 4 ohm load over a bandwidth of 20Hz-20KHz at a rated RMS sum total harmonic distortion of .07% of the fundamental output voltage, both channels operating.

Frequency Response: $\pm 0.1\text{dB}$ 20Hz-20KHz, @ 1 watt, 8 ohms.
+0, -3dB 5Hz-100KHz, @ 1 watt, 8 ohms.

1 KHz Power: 60 watts RMS into 8 ohms; both channels operating, 0.01% Total Harmonic Distortion.

Harmonic Distortion: Less than 0.001% from 20Hz-400Hz, increasing linearly to 0.05% at 20KHz at 50 RMS (per channel) into 8 ohms.

IM Distortion (60Hz & 7KHz, 4:1): Less than .00095% from 0.25 watts to 50 watts.

Slewing Rate: 6 volts per microsecond.

Damping Factor: Greater than 400, from DC to 400Hz, into 8 ohms.

Output Impedance: Less than 20 milliohms in series with less than 3 microhenries.

Load Impedance: Rated for 8 and 4 ohm usage; safely drives any load including reactive loads.

Voltage Gain: 20.6 ($=26.3\text{dB} \pm 0.2\text{dB}$) at maximum gain.

Input Sensitivity: 1.0 volts $\pm 2\%$ for 50 watts into 8 ohms.

Output Power (16 ohms): 100 watts minimum RMS into an 16 ohm load over a bandwidth of 20Hz-20KHz at a rated RMS sum total harmonic distortion of 0.07% of the fundamental output voltage.

Monaural Specifications

Output Power (8 ohms): 160 watts minimum RMS into a 8 ohm load over a bandwidth of 20Hz-20KHz at a rated RMS sum total harmonic distortion of 0.10% of the fundamental output voltages.

Frequency Response: $\pm 0.1\text{dB}$ 20Hz-20KHz, 1 watt, 16 ohms.
+0, -3dB 5Hz-100KHz, 1 watt, 16 ohms.

1KHz Power: 120 watts RMS into 16 ohms; .02% Total Harmonic Distortion.

Harmonic Distortion: Less than .0015% from 20Hz-400Hz, increasing linearly to .07% at 20KHz, 100 watts RMS into 16 ohms.

IM Distortion (60Hz & 7KHz, 4:1): Less than 0.0015% from .25 watts to 100 watts.

Slewing Rate: 12 volts per microsecond.

Damping Factor: Greater than 400, from DC to 400Hz, into 16 ohms at main outputs.

Output Impedance: Less than 40 milliohms in series with less than 6 microhenries at main outputs.

Load Impedance: Rated for 8 and 16 ohm usage; safely drives any load including completely reactive loads.

Voltage Gain: 41.2 ($32.3\text{dB} \pm 0.2\text{dB}$) at maximum gain.

Input Sensitivity: 1.0 volts $\pm 2\%$ for 100 watts into 16 ohms.

Mono Mode Signal Path: Channel 1 VOLUME control and input jack are active, channel 2 inactive (but not cut out); output cables are connected across (+) terminals of Left and Right channels.



IV. Panel Configuration

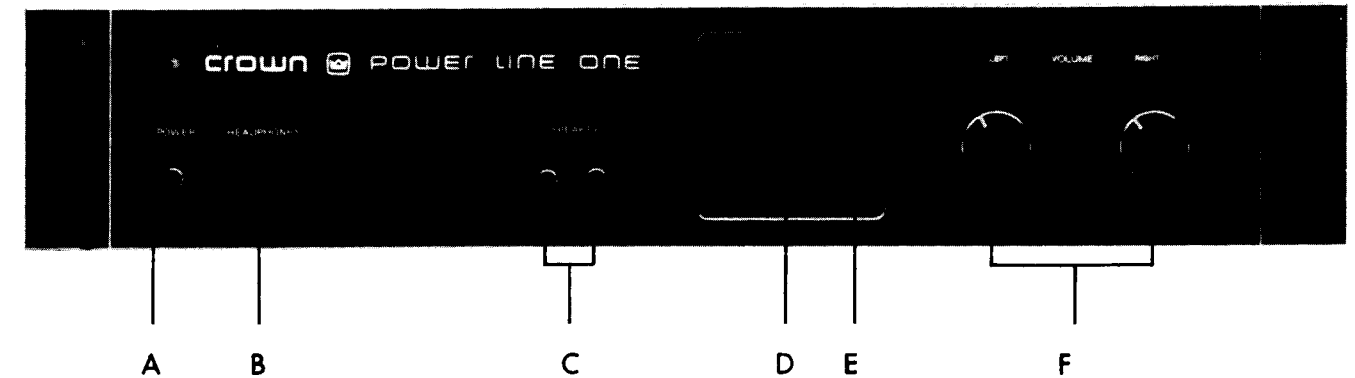

Fig. RVW.1 PL-1 Front Panel

- A. POWER SWITCH and INDICATOR LIGHT
- B. HEADPHONE JACK
- C. SPEAKER 1 and 2 ON/OFF SWITCHES
- D. OUTPUT LEVEL INDICATORS
- E. IOC INDICATORS
- F. VOLUME CONTROLS

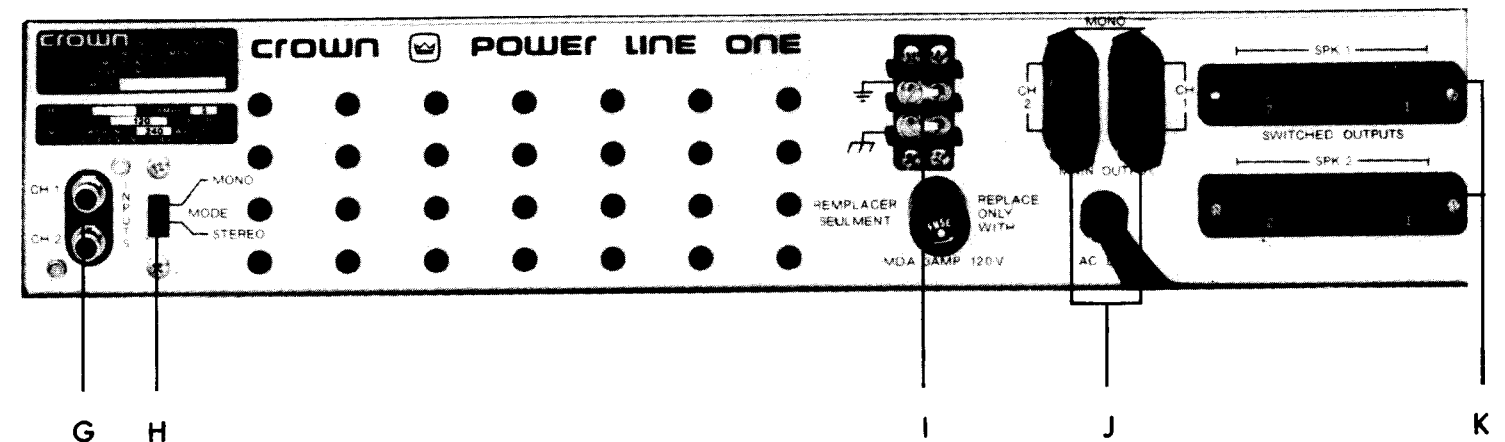
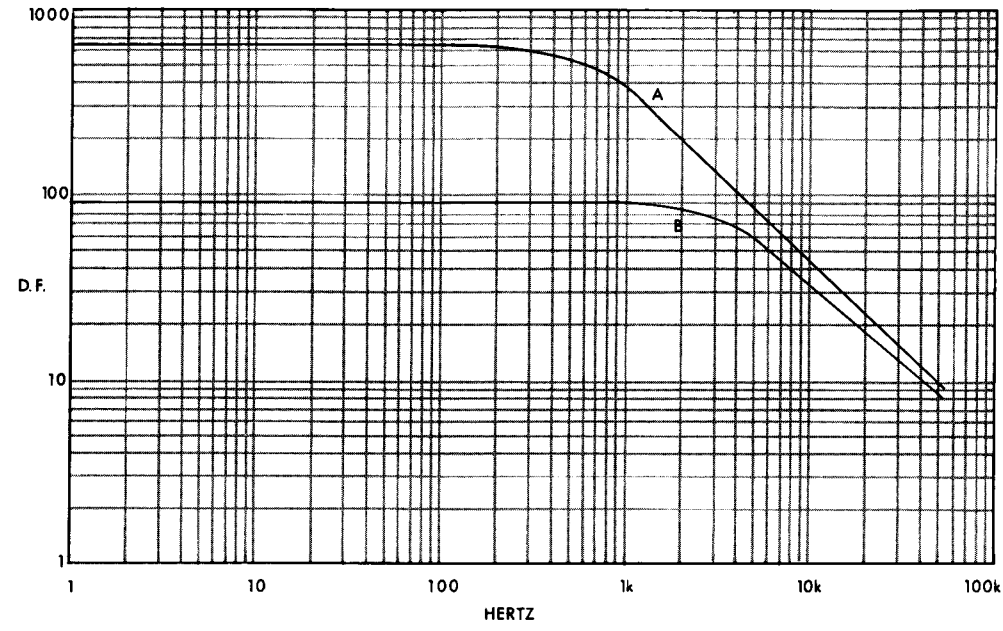

Fig. RVW.2 PL-1 Rear Panel

- G. INPUT JACKS
- H. MONO-STEREO MODE SWITCH
- I. CHASSIS GROUND STRAP BLOCK
- J. MAIN UNSWITCHED OUTPUT TERMINALS
- K. SWITCHED OUTPUT TERMINALS

V. Performance Graphs



Main Output Port = "A" Slope
Speaker 2 Output Port = "B" Slope

Fig. RVW.3 Damping Factor

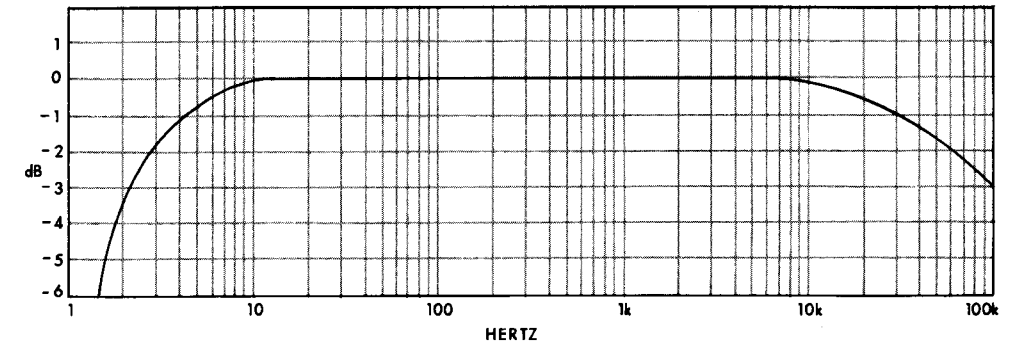
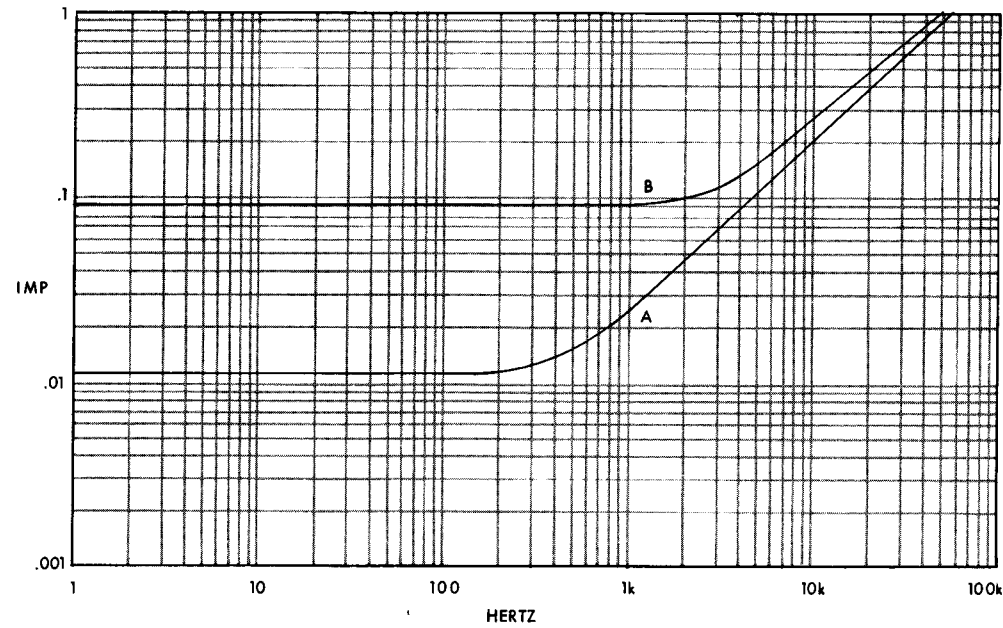

Fig. RVW.5 Frequency Response;
1 watt 8 ohms



Main Output Port = "A" Slope
Speaker 2 Output Port = "B" Slope

Fig. RVW.4 Output Impedance (ZO)



SECTION 6

ILLUSTRATED PARTS LIST

6.1 General Information

Section 6 contains illustrations and parts lists for the PL-1. This information should be used with the service, repair and adjustment procedure in Section 7.

Most of the mechanical and structural type parts are illustrated and indexed on exploded view drawings. Electrical and electronic parts on these illustrations are also identified by the circuit reference designation next to the illustration. Both the index number and the reference designation are included in the parts list in separate columns. The reference designations correspond to those shown in schematic diagrams in the Review Section.

Electrical and electronic parts located on printed circuit boards are illustrated by schematic symbols on the trace side and by component shape symbols on the component side. Reference designations also appear on these diagrams.

The quantity of each part used in each location is also shown in the parts listing.

6.2 Standard and Special Parts

Many electrical and electronic parts used in the PL-1 are standard items stocked by and available from electronic supply houses. However, some electronic parts that appear to be standard, are actually special. A part ordered from Crown will assure an acceptable replacement. Structural items, covers and panels are available from Crown only.

6.3 Ordering Parts

When ordering parts, be sure to give the amplifier model and serial number and include the part description and Crown Part Number (CPN) from the parts list. Price quotes are available upon request.

6.4 Shipment

1. Shipment will be made by UPS or best method unless you specify a preferred method.
2. Shipments are made F.O.B. Elkhart, Indiana only.
3. Established Crown accounts will be freight prepaid and billed unless shipped by truck or air freight.
4. All others will be shipped freight collect.

6.5 Terms

1. Normal terms are C.O.D. unless the order is prepaid.
2. Net 30 days terms apply only to those firms who have an established line of credit with Crown.
3. If prepaying please add an amount for the freight charge. \$1.00 is average for an order under one pound.

NOTE: Part prices are subject to change without notice.

4. New parts returned for credit are subject to a 10% restocking charge.
5. You must receive authorization from the Parts Dept. before returning parts for credit.
6. We are not a general parts warehouse! Parts are available for servicing Crown products only.

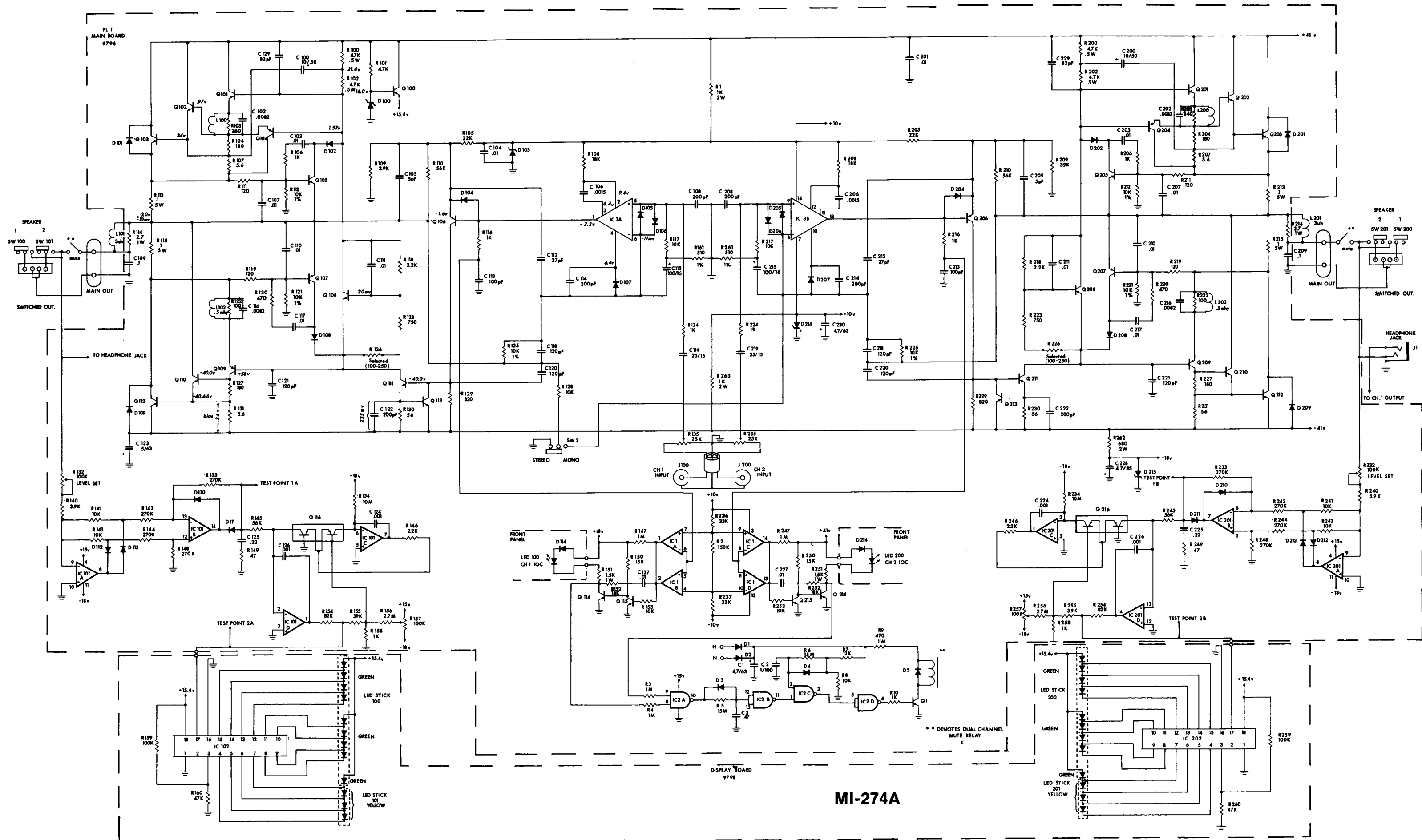

Fig. 6.2 PL-1 Main Schematic

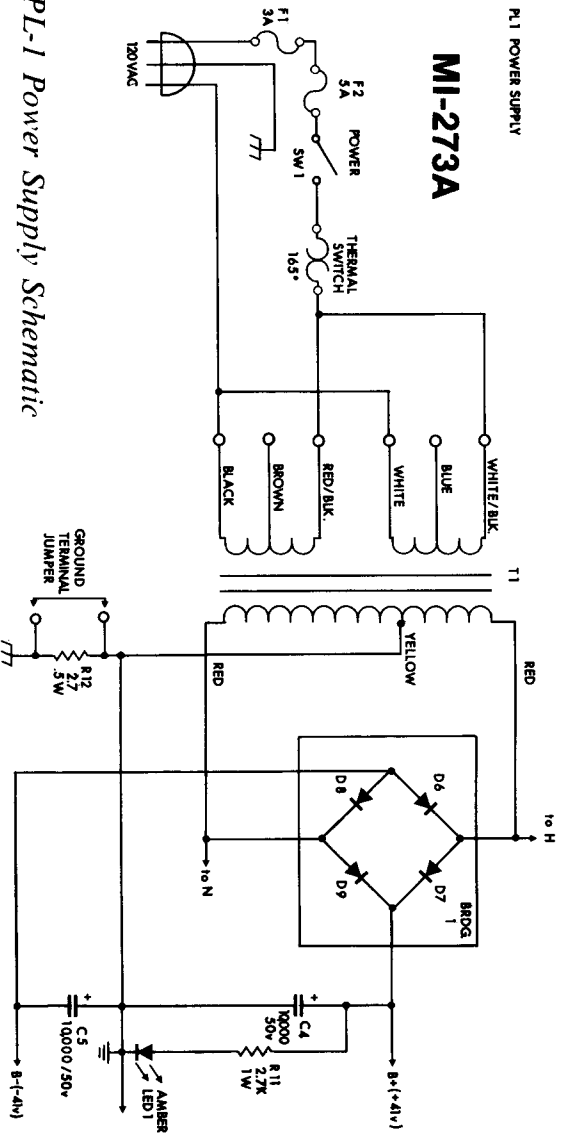

Fig. 6.1 PL-1 Power Supply Schematic

SCHEMATIC NOTES

- CIRCUIT SHOWN STARTS WITH SN1250 AND APPLIES ONLY TO PC BOARD #9796 (MAIN BOARD).
 - ALL RESISTORS ARE IN OHMS, ALL CAPACITORS ARE IN MICROFARADS, UNLESS OTHERWISE NOTED.
 - ALL RESISTORS ARE .25 WATTS UNLESS OTHERWISE NOTED.
 - COMPONENTS COMMON TO BOTH CHANNELS ARE NUMBERED FROM 1 TO 99.
 - LEFT CHANNEL COMPONENTS ARE NUMBERED FROM 100 TO 199.
 - RIGHT CHANNEL COMPONENTS ARE NUMBERED FROM 200 TO 299.
- DC VOLTAGES ARE SHOWN FOR VARIOUS POINTS. THESE ARE NOMINAL OPERATING VOLTAGES UNDER THE FOLLOWING CONDITIONS:
 - A)AC VOLTAGE INPUT IS 120V RMS.
 - B)LEVEL CONTROLS ARE FULL COUNTER-CLOCKWISE (NO INPUT).
 - C)OPERATING WITHOUT A LOAD.
 - D)MEASUREMENTS TAKEN WITH HIGH - Z INPUT DIGITAL VOLTMETER.
 - WIRE COLOR CODES ARE GIVEN FOR THE MAIN POWER SUPPLY.
 - SPEAKER "SWITCHED OUTPUT" SLIDE SWITCH SHOWN IN ACTIVE (OUT).
 - SW1 STEREO-MODE SLIDE SWITCH SHOWN IN STEREO.
 - MUTE RELAY SHOWN INACTIVE (NORMALLY OPEN).
 - GROUND STRAP SHOWN CONNECTED.

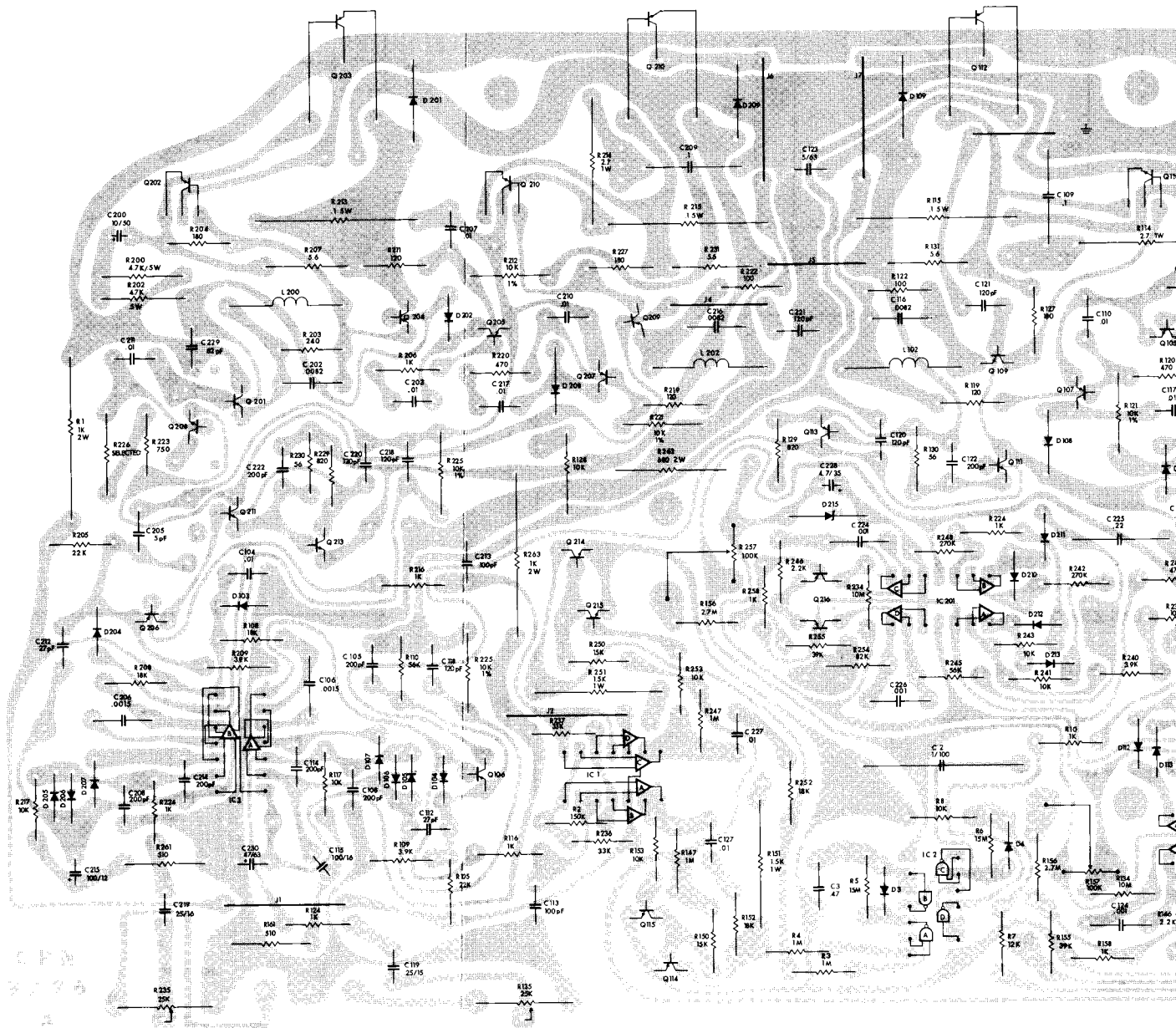

Fig. 6.4 Main Foil Board Layout

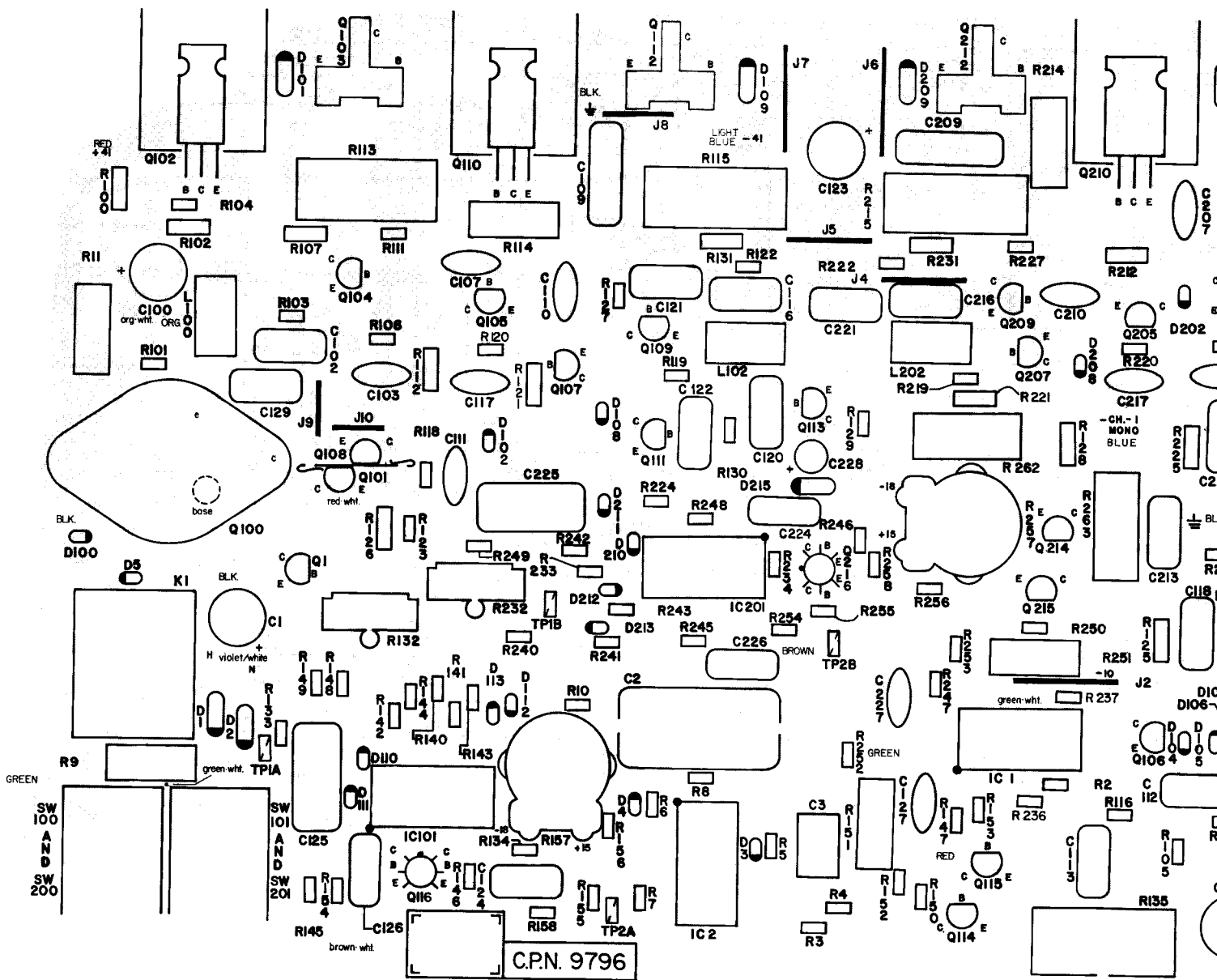

Fig. 6.3 Main Component Board
Layout

Schematic Designation	Description	Crown Part No.	Qty.
R1, R263	1K ohm 2 Watt	C 2555-8	2
R2	150K ohm ¼ Watt	C 4216-5	1
R3, R4, R147, R247	1M ohm ¼ Watt	C3198-6	4
R5, R6	15M ohm ¼ Watt	C 4661-2	2
R7	12K ohm ¼ Watt	C 2878-4	1
R8, R117, R217, R141, R241, R143, R243, R153, R253	10K ohm ¼ Watt	C 2631-7	9
R9	470 ohm 1 Watt	C 3765-2	1
R10, R106, R206, R116, R216, R124, R224, R158, R258	1K ohm ¼ Watt	C 2627-5	9
R11	2.7K ohm 1 Watt	C 1079-0	1
R12	2.7 ohm ½ Watt	C 2857-8	1
R100, R200, R102, R202	4.7K ohm ½ Watt	C 1640-9	4
R101	4.7K ohm ¼ Watt	C 3939-3	1
R103, R203	240 ohm ¼ Watt 5%	C 4513-5	2
R104, R204, R127, R227	180 ohm ¼ Watt	C 2873-5	4
R105, R205	22K ohm ¼ Watt	C 3302-4	2
R107, R207, R131, R231	5.6 ohm ½ Watt	C 3299-2	4
R108, R208, R152, R252	18K ohm ¼ Watt	C 2633-3	4
R109, R209, R140, R240	3.9K ohm ¼ Watt	C 2630-9	4
R110, R210, R145, R245	56K ohm ¼ Watt	C 2882-6	4
R111, R211, R119, R219	120 ohm ¼ Watt	C 4723-0	4
R112, R212, R121, R221, R125, R225, R128	10K ohm ½ Watt 1%	C 2343-9	7
R113, R213, R115, R215	.1 ohm 5 Watt	C 3291-9	4
R114, R214	2.7 ohm 1 Watt	C 1001-4	2
R118, R218, R146, R246	2.2K ohm ¼ Watt	C 2628-3	4
R120, R220	470 ohm ¼ Watt	C 2626-7	2
R122, R222	100 ohm ¼ Watt	C 2872-7	2
R123, R223	750 ohm ¼ Watt	C 3803-1	2
R126, R226	Selected		2
R129, R229	820 ohm ¼ Watt	C 3301-6	2
R132, R232	100K ohm Vertical Pot	C 1713-4	2
R133, R233, R142, R242, R144, R244, R148, R248	270K ohm ¼ Watt	C 2885-9	8

Schematic Designation	Description	Crown Part No.	Qty.	Other Information
R134, R234	10M ohm ¼ Watt	C 3221-6	2	
R135, R235	25K ohm Audio Pot	C 4936-7	2	Input level controls
R236, R237	33K ohm ¼ Watt	C 4346-0	2	
R149, R249	47 ohm ¼ Watt	C 1011-3	2	
R150, R250	15K ohm ¼ Watt	C 2632-5	2	
R151, R251	1.5K ohm 1 Watt	C 3497-2	2	
R154, R254	82K ohm ¼ Watt	C 4212-4	2	
R155, R255	39K ohm ¼ Watt	C 2879-2	2	
R156, R256	2.7M ohm ¼ Watt	C 2634-1	2	
R157, R257	100K ohm Horizontal Pot	C 1709-2	2	
R161, R261	510 ohm ½ Watt	C 3304-0	2	
R262	680 ohm 2 Watt	C 5222-2	1	
Capacitors				
C1, C123, C230	4.7mF 63V Vertical	C 4253-8	3	
C2	1mF 100V Filmatic	C 3008-7	1	
C3	.47mF 100V Polycarb	C 4119-1	1	
C4, C5	10,000mF 50V	C 4960-8	2	
C100, C200	10mF 50V Vertical	C 3728-0	2	
C102, C202, C116, C216	.0082mF 200V Filmatic	C 3063-2	4	
C103, C203, C104, C201, C107, C207, C110, C210, C111, C211, C117, C217, C127, C227	.01mF Ceramic Disc	C 1751-4	14	
C105, C205	5pF Mica	C2820-6	2	
C106, C206	.0015mF 200V Filmatic	C 3089-7	2	
C108, C208, C114, C214, C122, C222	200pF Mica	C 3411-3	6	
C109, C209	.1mF 200V Filmatic	C 2938-6	2	
C112, C212	27pF Mica	C 2342-1	2	
C113, C213	100pF Mica	C 3410-5	2	
C115, C215	100mF 16V Vertical	C 3729-8	2	
C118, C218, C120, C220, C121, C221	120pF Mica	C 3290-1	6	
C119, C219	22mF 50V N-P Vertical	C 5311-3	2	
C124, C224, C126, C226	.001mF 200V Filmatic	C 3480-8	4	
C125, C225	.22mF 100V Filmatic	C 3218-2	2	
C228	4.7mF 35V Tantalum	C 4019-3	1	
C129, C229	82pF Mica	C 3627-4	2	
Switches				
Thermal Switch	SPST 165° Thermal Switch	C 2799-2	1	
SW1	PL-1 Power Switch	D 4809-6	1	On/Off
SW2	DPDT Flush Mount	C 4992-1	1	Mono/Stereo switch
SW100, SW200, SW101, SW201	2 Station DPDT Pushbutton	D 4810-4	1	Speaker selection

Schematic Designation	Description	Crown Part No.	Qty.
Diodes			
D1, D2, D101, D201, D109, D209	IN4004	C 2851-1	6
D3, D4, D5, D102, D202, D104, D204, D105, D205, D106, D206, D107, D207, D110, D210, D111, D211, D112, D212, D113, D213	IN4148	C3181-2	21
(D6, D7, D8, D9) Br. 1	VH148 6A Bridge	C 3062-4	1
D100	IN966B 16V Zener	C 3533-4	1
D103, D216	IN961B 10V Zener	C 3549-0	2
D108, D208	IN270	C 3447-7	2
D215	IN4746 18V Zener	C 4980-6	1
Transistors			
Q1, Q105, Q205, Q108, Q208, Q111, Q211, Q113, Q213, Q114, Q214, Q115, Q215	SEL 2N3958A NPN	D 2961-7	13
Q100 Q103, Q203, Q112, Q212	MJ15015 NPN	C 4751-1	5
Q101, Q201	MPSA06	C 3528-4	2
Q102, Q202, Q110, Q210	TIP 47 NPN	C 4647-1	4
Q104, Q204, Q107, Q207	2N4125 PNP	C 3625-8	4
Q116, Q216	SEL IT132 PNP	D 4837-7	2
Integrated Circuits			
IC1-A,B,C,D	LM339N Voltage Comparator	C 4345-2	1
IC2-A,B,C,D	4011 Quad 2 Input Nand	C 4529-1	1
IC101-A,B,C,D IC201-A,B,C,D	TL074	C 4696-8	2
IC3-A,B	TBA 231 Dual Op Amp	C 5368-3	1
Fuses			
F1	MDA 3 amp Fuse	C 4384-1	1
F2	AGC 5 amp Fuse	C 3774-4	1
Coils			
L101, L201	3uh Coil	M42018-8	2
L100, L200, L102, L202	.5mh Axial	C 3510-2	4

Parts List: Main Board/Miscellaneous

Schematic Designation	Description	Crown Part No.	Qty.	Other Information
LED's				
LED 1	MV5153 Amber LED	C 4342-9	1	Power indicator
Miscellaneous				
T1	Power Transformer	D 4817-9	1	
Mute Relay	DPDT 24VDC Relay	C 4979-8	1	Mute Relay
	MOD 3 Receptacle	C 5340-2	2	
	.187 Shrink Tube	B 1361-3		
	14 Pin DIP Socket	C 3450-1	5	
	PC Receptacle	C 3519-3	4	
	AMPMOD 1 Pin Header	C 5001-0	4	
	R4-40 .37 Machine Screw	C 1844-7	2	
	#4 Internal Star Washer	C 1824-9	2	
	4-40 Hex Nut	C 1983-7	2	
	Dual T092 Cooler	C 3493-1	2	

Parts List: Display Board

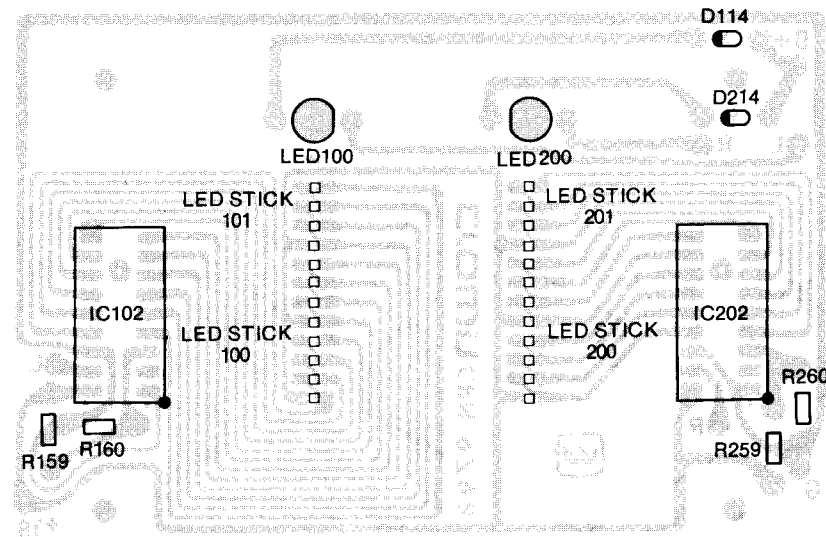

Fig. 6.5 Display Component Board Layout

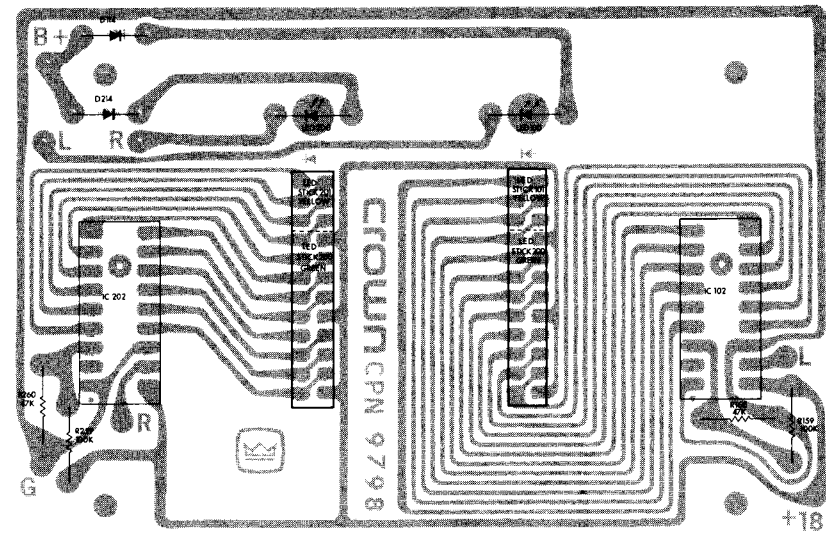
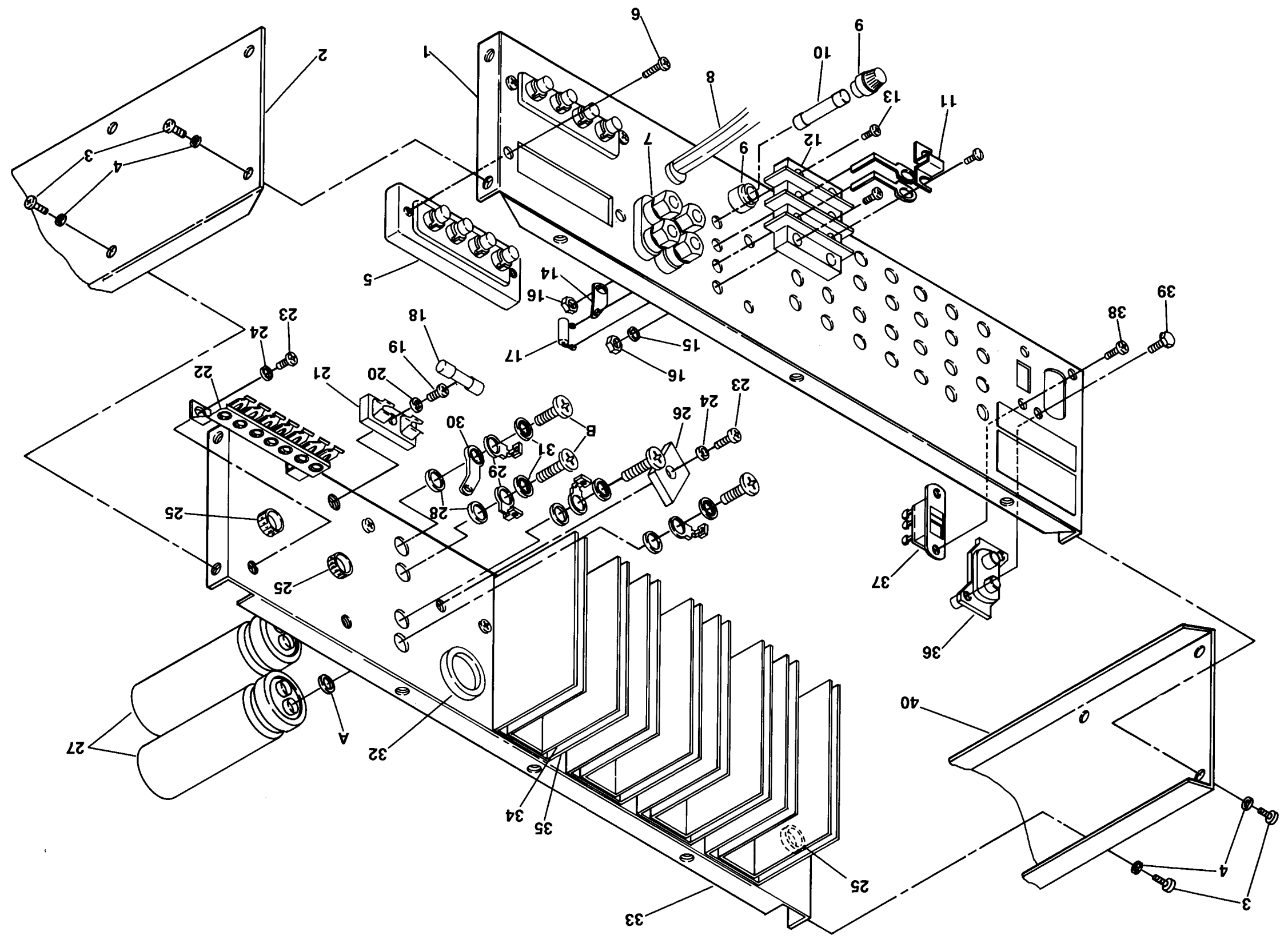

Fig. 6.6 Display Foil Board Layout

Schematic Designation	Description	Crown Part No.	Qty.	Other Information
Resistors				
R159, R259	100K ohm .25W 5%	C 2883-4	2	
R160, R260	47K ohm .25W 5%	C 2880-0	2	
Integrated Circuits				
IC102, IC202	UAA180 LED Display Driver	C 4981-2	2	
Diodes				
D114, D214	IN4148	C 3181-2	2	
LED's				
LED100, LED200	MV5053 Red LED	C 4341-1	2	Overload (IOC) indicator
LED Stick 100, 200	9 Element LED Stick	C 4975-6	2	Green
LED Stick 101, 201	3 Element LED Stick	C 4974-9	2	Green
Parts List: Accessories				
	510 32 .75 Machine Screw	C 2044-3	4	
	.156 Hex Allen Wrench	C 5023-4	1	
	.350x.185x.060 Fiber Washer	D 4957-3	4	
	3AG 1.5 Amp Fuse	C 2957-6	2	
	Dual Banana Plug	C 2981-6	2	
	Pigtail Fuseholder	C 3060-8	2	
	6 Foot Pin-Pin Cable	D 3338-7	2	
	Wire Nut	S 3069-2	2	

Fig. 6.7 Back Panel Assembly



Parts List: Back Panel Assembly

Index No.	Schematic Designation	Description	Crown Part No.	Qty.	Other Information
1		PL-1 AP Back Chassis	M20131-5	1	
2		PL-1 Left Side Panel	M20132-3	1	
3		R6 32 .25 Machine Screw	C 1954-4	14	Misc. mounting
4		#6 Internal Star Washer	C 5594-4	49	Misc. mounting
5		4 Way Wire Lock Connector	D 4984-7	2	
6		B 6P .37 Self-tapping Screw	C 4664-6	4	
7		Dual Binding Post	C 2823-0	2	
8		3-18 8 Foot Power Cord	D 3474-0	1	
9		HTA Fuseholder	C 3256-2	1	
10	F1	3 Amp Fuse	C 4384-1	1	
11		Barrier Block Jumper	C 4726-3	1	
12		Barrier Block	C 3489-9	1	
13		R6 32 .50 Machine Screw	C 2176-3	4	
14		Solder Lug #8 Hole	D 2935-1	1	
15		#6 Internal Star Washer	C 5594-4	3	
16		6-32 Hex Nut	C 1889-2	4	
17	R12	2.7 ohm .5W 5%	C 2857-8	1	
18	F2	5 Amp Fuse	C 3774-4	1	
19		R6 32 .50 Machine Screw	C 2176-3	1	
20		#6 Internal Star Washer	C 5594-4	1	
21		Fuse Block	C 3776-9	1	
22		Terminal Strip	D 5625-5	1	
23		R6 32 .37 Machine Screw	C 2134C6	2	
24		#6 Internal Star Washer	C 5594-4	2	
25		.500-6 Snap Bushing	C 3816-3	3	
26	Brdg. 1	VH148 6A Bridge	C 3062-4	1	
27	C4, C5	10,000mF 50V	C 4960-8	2	
28		Fiber Washer	C 3575-5	4	
29		389 Solder Lug	D 2934-4	4	
30		762 Solder Lug	D 3515-0	1	
31		#6 Star Washer	C 5594-4	4	
32		Grommet	C 2658-0	1	
33		Heat Sink Panel	M20083-8	1	
34		Heat Sink Inner	F 9815-6	4	
35		Heat Sink Outer	F 9816-4	4	
36		2 Way Phono Jack Plate	C 4933-5	1	
37		DPDT Switch	C 4992-1	1	
38		R6 32 .25 Machine Screw	C 1954-4	2	
39		B4H .37 Self-tapping Screw	C 4895-6	2	
40		PL-1 Right Side Panel	M20085-3	1	
A		Fiber Shoulder Washer	C 1648-2	4	
B		T10 32 .50 Machine Screw	C 2049N2	4	

Parts List: Front Panel Assembly

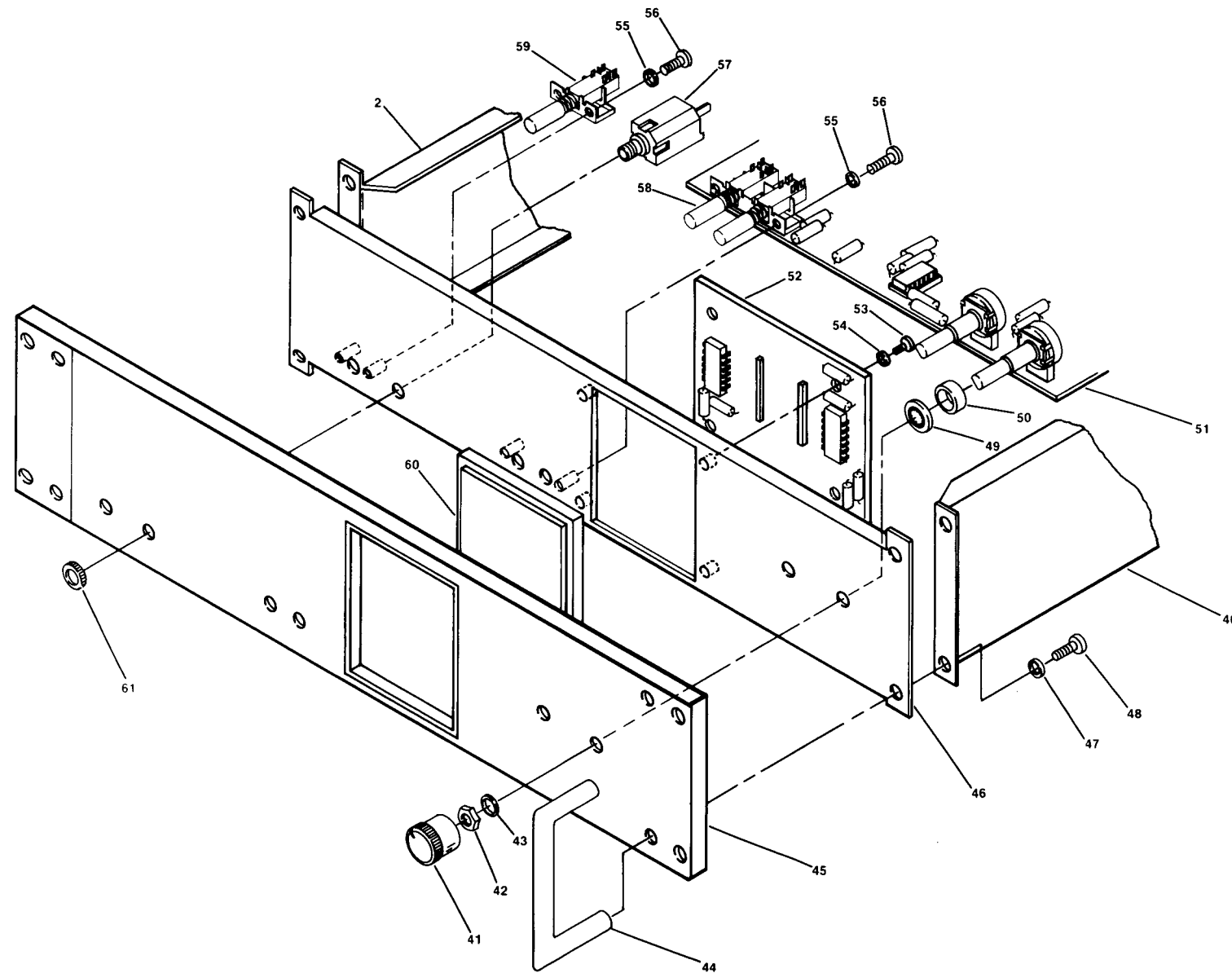

Index No.	Schematic Designation	Description	Crown Part No.	Qty.	Comments
41		1 inch Aluminum Knob	D 4820-3	2	PL-1 only
41		1 inch Aluminum Knob	D 5331-0	2	PL-1S only
42		.375 Bright Nut	C 1288N7	2	
43		.625x375x030 Washer	C 2189-6	2	
44		Round Handle, Black	D 4818-7	2	PL-1 only
44		Round Handle, Silver	D 5329-4	2	PL-1S only
45		Front Panel	F 9822J1	1	PL-1 only
45		Front Panel	F 9889J0	1	PL-1S only
46		Sub-front Panel	M20086-1	1	
47		#8 Internal Star Lockwasher	C 1951-0	4	
48		S8 32 .75 Machine Screw	C 5024-2	4	
49		.375 Internal Star Washer	C 2188-8	2	
50		.625x.406x.345 Brass Spacer	D 3210-8	2	
51		Main Board Module	Q42011-9	1	
52		Display Board Module	Q42025J8	1	
53		R6 32 .25 Machine Screw	C 1954-4	4	
54		#6 Internal Star Washer	C 5594-4	4	
55		#4 Internal Star Lockwasher	C 1824-9	4	
56		R4 40 .37 Machine Screw	C 1844-7	4	
57		3 Conductor Jack	C 3507-8	1	Headphone jack
58		Black Pushbuttons	D 4819-5	3	PL-1 only
58		Silver Pushbuttons	D 4074-7	3	PL-1S only
59		Power Microswitch	D 4809-6	1	On/Off
60		Display Lens Assembly	M42023-8	1	
61		.375 Knurled Nut	C 3495B2	1	

Fig. 6.8 Front Panel Assembly

Parts List: Heatsink Assembly

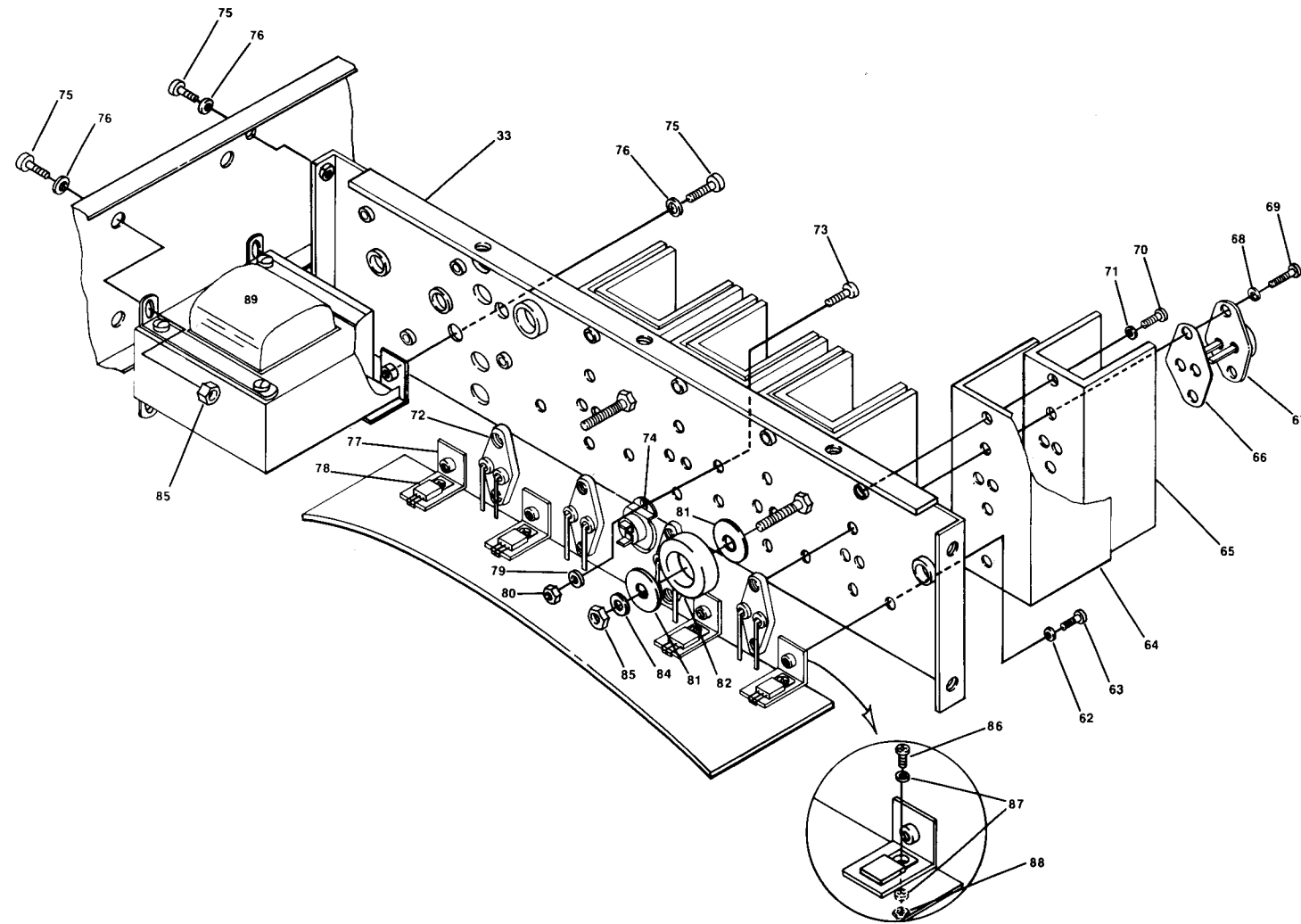

Fig. 6.9 Heatsink Assembly

Index No.	Schematic Designation	Description	Crown Part No.	Qty.	Other Information
62		#4 Internal Star Lockwasher	C 1824-9	4	
63		R4 40 .37 Machine Screw	C 1844-7	4	
64		Heat Sink Outer	F 9816-4	4	
65		Heat Sink Inner	F 9815-6	4	
66		Anode Shoulder T03 Insulator	C 4039-1	4	
67	Q103, Q203, Q112, Q212	MJ5015 Power NPN	C 4751-1	4	
68		#4 Internal Starwasher	C 1824-9	8	
69		M3x5x16MM Screw	C 5026-7	8	
70		R6 32 .37 Machine Screw	C 2134C6	8	
71		#6 Internal Star Washer	C 5594-4	8	
72		TO-3 PC Mount Socket	C 4934-3	4	
73		R4 40 .37 Machine Screw	C 1844-7	2	
74		SPSTNC 160°F Thermal Switch	C 2799-2	1	Thermal Switch
75		T8 32 .37 Machine Screw	C 2155-7	5	
76		#8 Internal Star Lockwasher	C 1951-0	8	
77		Heat Sink Bracket	M20107-5	4	
78		TIP 47	C 4647-1	4	
79		#4 Internal Star Washer	C 1824-9	2	
80		4-40 Hex Nut	C 1938-7	2	
81		875x187 Fiber Washer	D 3609-1	4	
82		Torroid Form	C 2850-3	1	
84		#10 Internal Star Washer	C 2279-5	2	
85	8-32 Hex Nut	C 1986-6	2		
86		R4 40 .37 Machine Screw	C 1844-7	4	
87		#4 Internal Star Washer	C 1824-9	4	
88		4-40 Hex Nut	C 1938-7	4	
89	T1	Power transformer	D 4817-9	1	

Parts List: Final Assembly

Index No.	Schematic Designation	Description	Crown Part No.	Qty.	Comments
92		Top Cover	F 9823-0	1	
93		Bottom Cover	F 9824-8	1	
94		R6 32 .25 Machine Screw	C 1954-4	22	
95		#6 Internal Star Washer	C 5594-4	22	
96		Black Feet	C 5199-2	4	

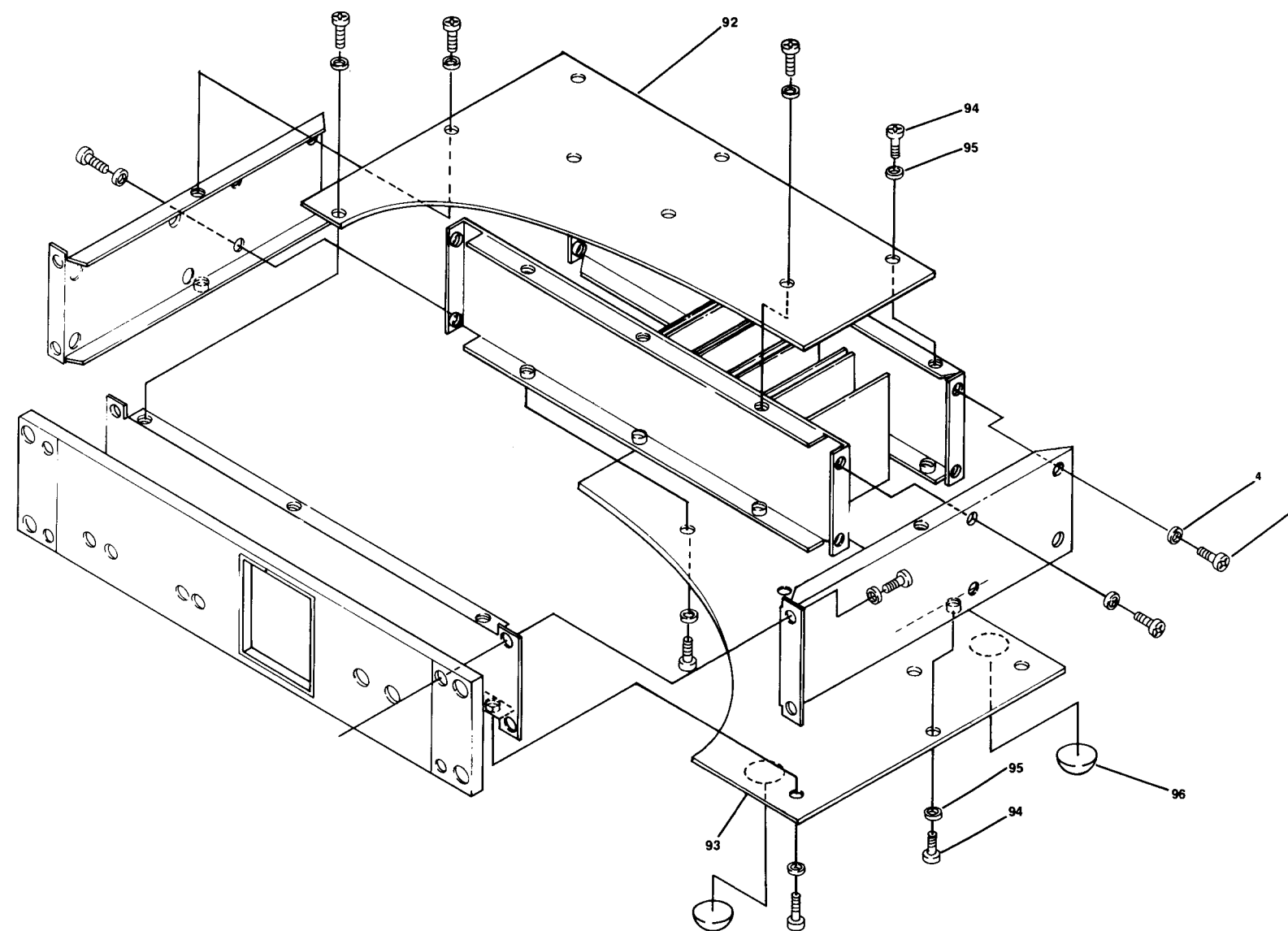

Fig. 6.10 Final Assembly



SECTION 7 MAINTENANCE

7.1 Introduction

Section 7 contains technical information required to effectively and efficiently service and repair the Crown PL-1. Included are disassembly and reassembly procedures, required test equipment lists, checkout procedures, basic troubleshooting tips and a soldering technique review.

THIS INFORMATION IS INTENDED FOR USE BY AN EXPERIENCED TECHNICIAN ONLY!

Use this information in conjunction with the Instruction Manual, schematic/board layout diagrams, parts lists and exploded view drawings (the latter located in Section 6 of this manual).

7.2 Required Test Equipment

Many of the service and repair problems with the PL-1 can be performed with a limited amount of test equipment. However, in order to return the unit to its "factory new" specifications, the following list of required test equipment is recommended. The "Requirements" column provides information to allow intelligent selection of substitutes if the "Suggested Supplier and Model" is not available or is considered impractical to obtain.

EQUIPMENT	REQUIREMENTS	APPLICATION	SUGGESTED MODEL
Oscilloscope	Capable of displaying a 10MHz signal	Monitoring output during service and testing	Telequipment D54A or equivalent
Volt-ohmmeter (VOM)	Low-voltage resistance probe (100mv range). High-voltage resistance probe (1.5V range)	Check resistance values (low voltage probe). check semiconductor junctions for opens or shorts (high voltage probe) Check DC voltages	Triplet 601 or equivalent
Freq. Counter		For accurate general monitoring	Heath SM118A
Signal Generator	Sine/Square wave available; flat frequency response. THD. .1% maximum	Provide test signals for service and checkout	Wavetek 130-Series or equivalent
Circuit Breaker	15 ampere rating	In AC line to unit; protects circuitry from overload if power supply has shorted	
AC Line Voltage Monitor	Peak reading meter (displays rms equivalent to a sinusoidal peak from any wave form)	Monitor Line voltage	Available from CROWN

EQUIPMENT	REQUIREMENTS	APPLICATION	SUGGESTED MODEL
Phase Meter			
AC Voltmeter	100mv low range, flat frequency response to 100KHz	Set output level for testing; check noise level	Hewlett-Packard 400F or equivalent
Filter	20-20KHz bandpass, low noise 20Hz-20KHz	Between preamplifier and voltmeter in noise test	Information available from CROWN
Intermodulation Distortion Analyzer	Residual (.00095)	Check IM distortion	Information available from Crown

especially obnoxious when measuring distortion. An IM analyzer for example has its input and output terminals tied to a common ground. Such a test should use an ungrounded output return with the output lead wrapped around a well-shielded and grounded input cable (See Section 7.9 for additional information).

7.3 Soldering Techniques

Note: Proper continuity between internal components of any electronic device is the key to its successful operation. Therefore, a brief review of the following discussion on soldering techniques may be in order. Because most service work involves component part(s) replacement, hand-soldering with the use of a soldering iron will be the only method covered, even though many exist.

The difference between success and failure in service repair is often determined by the thermal characteristics of an iron and how well it matches the job at hand. One would not use a large flat-head screwdriver to work on a delicate Swiss watch. Likewise, the proper size iron and tip should be used when soldering delicate electronic parts in position.

Iron wattage classification is actually not a very good method of choosing an iron. The reason for this is because of the possible inefficiency of heat transfer to the tip internally. A large wattage iron (125W) may, in effect produce lower tip temperatures than another iron smaller in wattage. Likewise, tip size and shape does not necessarily work in proportion to temperature. Therefore, it is impractical to compare soldering irons by their wattage but more feasible to refer to them by their maximum tip temperature.

Usually, the skilled service technician can pick the right iron and tip for the job from experience or recommendation. In most cases, the miniature or small electrical soldering iron will work well with delicate semiconductor devices (Fig. 7.1). When the proper size iron is used (usually around 700° F. tip temperature), a joint is almost instantly heated (approx. 500-550°) and application of iron and solder melting is simultaneous.

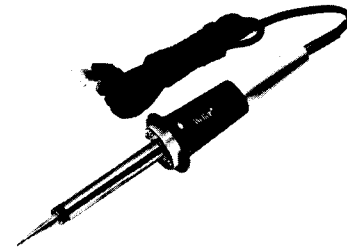

Fig. 7.1 Miniature Soldering Iron

When clean metal is exposed to air a chemical reaction takes place known as oxidation. When heat is applied to metal, oxidation is speeded up and creates a non-metallic film that prevents solder from touching the base metal. By applying a small amount of solder to a hot iron tip, a desirable process known as tinning occurs. The main reason for tinning an iron is to help prevent it from oxidation as well as to aid in heat transfer. Tinning should be performed prior to each use as well as after long idling times.

To help prevent oxidation or remove existing oxidation while soldering, a natural rosin flux core solder should be used. Not only does flux aid in cleaning, but acts as a catalyst in that it helps speed up the joint formation without actually entering itself, into the bond. Never use an acid flux except to clean a highly oxidized tip that will not tin correctly. Crown recommends 63% tin/37% lead composition with a rosin flux core of 2.5% (melting temperature is approx. 361° F.).

Fig. 7.2 shows the correct and incorrect method of applying rosin flux core solder to a joint. Never apply solder to the iron tip directly and allow solder to run onto the joint (flux is burned away and does not clean the joints). Always apply heat to the connection and allow the joint to melt the solder, not the iron. This insures proper wetting and flow of the solder.

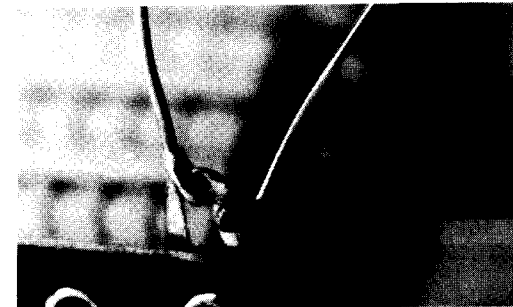
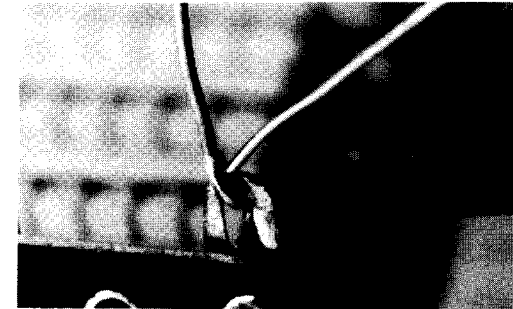

Fig. 7.2 Correct and Incorrect Solder Application

Problem: Unsoldered wire.

Characteristics: Properly assembled junction of wire, but without any solder.



Fig. 7.3 Unsoldered Wire

Cause: Solder not applied.

Remedy: Correct amount of solder applied properly.

Problem: External strands.

Characteristics: One or more strands of wire outside terminal. This defect most common when cup-type terminals are utilized.

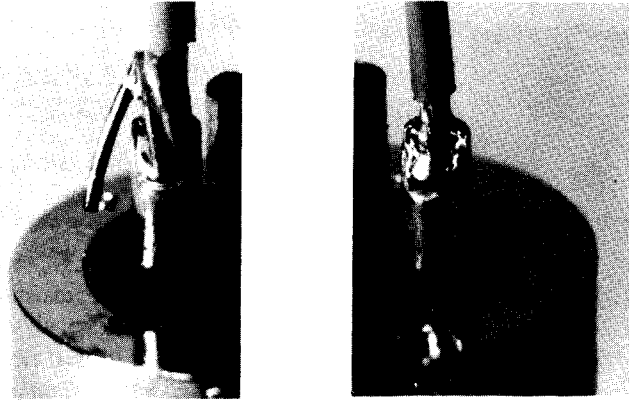

Fig. 7.4 External Strands

Cause: Poor assembly operation, too large diameter wire used.

Remedy: Correct diameter wire tinned prior to insertion.

Problem: Cut strands.

Characteristics: Several strands of wire cut or broken and usually not soldered to terminal.



Fig. 7.5 Cut Strands

Cause: Improper wire stripping; wire flexed or bent excessively during or after assembly.

Remedy: Use wire strippers similar to the one shown in Fig. 7.6. Care must be taken to avoid nicking or cutting.

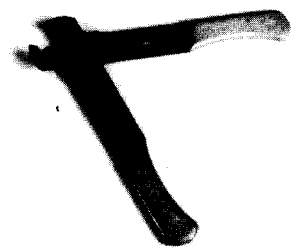

Fig. 7.6 Wire Strippers

Problem: Disturbed joint.

Characteristics: Rough appearance with questionable adhesion.

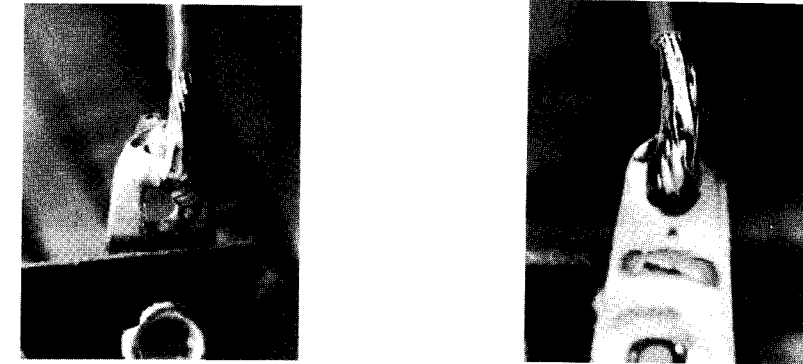

Fig. 7.7 Disturbed Joint

Cause: Movement of wire/joint during cool-off stage.

Remedy: Use of holding vice or similar tool to help prevent movement.

Problem: Cold solder joint.

Characteristics: Joint with dull, frosty appearance; often has poor adhesion as well as imperfect shaping.



Fig. 7.8 Cold Solder Joint

Cause: Too much heat applied (flux is boiled off before oxide removal action takes place).

Remedy: Correct matching of iron/tip to specific job. Correct solder flux combination is also important.

Problem: Rosin joint.

Characteristics: Joint is separated by a thin coat of flux producing high resistance to current.



Fig. 7.9 Rosin Joint

Cause: Solder applied previous to terminal reaching minimum temperature (solder melting point).

When soldering individual component parts to printed circuit boards, several procedures may be followed. The following procedure complies to U.S. Government standards and may be altered to suit a specific situation.

1. Components leads should be bent to exact spacing of mounting holes in PC board (Fig. 7.10). This allows leads to enter PC board at right angles and relieves stress.



Fig. 7.10 Component Lead Spacing

2. Leads should be bent down tight to pad.

3. Leads should be bent in the direction of the run connected to the pad and clipped at a length approximately $\frac{1}{8}$ " (Fig. 7.11).

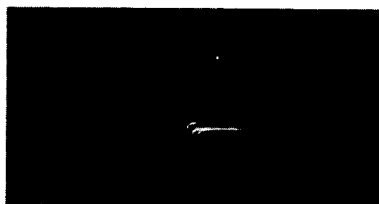
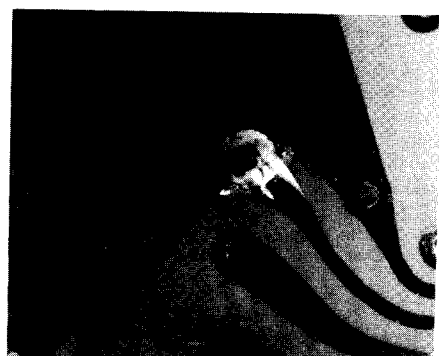

Fig. 7.11 Component Lead Bending



Remedy: Apply correct amount of heat; remove only after good wetting and fillet is achieved.

4. Components should be held tight to the PC board while clinching leads on other side (Fig. 7.12) and soldered accordingly. Fig. 7.13 shows acceptable solder joints.

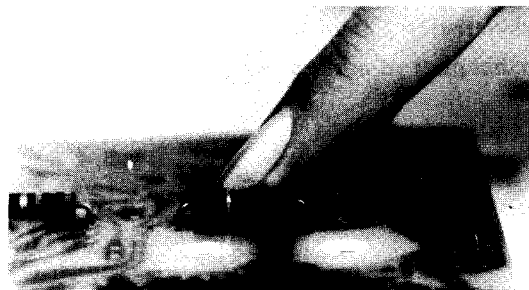

Fig. 7.12 Correct Pressure Applied



Fig. 7.13 Acceptable Solder Joints

When soldering to lugs (as on potentiometers), the mechanical wire wrap should be a J hook with correct insulation clearance as shown in Fig. 7.14.

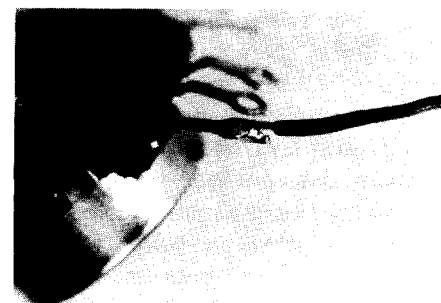

Fig. 7.14 Soldering to a Lug

Turret terminals also utilize the "J" hook (Fig. 7.15). Concentrate on good heat transfer to the terminal first, then the wire. If two wires are to be soldered, be sure of good solder flow to all three.



Fig. 7.15 Turret Terminal

Desoldering

In order to replace a component part, it is often necessary to remove the old part by means of desoldering. Several methods are available, the most common being the braided bare copper method. This wire braid is placed on the lead(s) of the component to be removed with the iron placed on top of the braided wire. This allows the solder to heat up while simultaneously adhering to the braid. When the braided wire is removed, the joint should be clean. (See Fig. 7.16)



Fig. 7.16 Wire Braid Desoldering

Next, use points of small diagonals to lift ends of component lead wires and remove the part. This procedure is applicable to both PC board desoldering as well as terminal and lug desoldering.

Note: Be sure that lifting of the component lead does not also lift the copper foil pad from the board. Occasionally a small amount of iron will be helpful.

Soldering is one of the most reliable methods of joining electronic component parts and assemblies. When properly used, it can be one of the most helpful tools in service repair work.

7.4 Basic Troubleshooting

As is well known, time is an important factor in providing efficient service repair. Therefore, several time-saving troubleshooting steps are listed below. These hints may or may not already be implemented in your service work. If not, you may wish to experiment with them in order to help improve your efficiency. After all, time is money!

A. Establishing Problems

User complaints about defective operation may not always be clear or simple. Furthermore, the trouble the user has experienced may be due to the system and not the unit itself. If possible, talk to the user about this problem. This will usually be simpler than trying to understand written complaints. A first hand account of the problem can help in:

- 1) Getting the problem to re-occur on the service bench.
- 2) Getting an understanding of the probable cause. Some troubles will be obvious upon visual inspection. When the trouble (or its symptoms) is not so obvious ask:
 - a) Exactly what was the problem; how was it noticeable?
 - b) How was the unit being used?
 - c) Has the system as a whole been carefully examined for possible external problems?
 - d) How long had the unit been operating when the problem occurred? Was it heat related?

If the user is unavailable or unable to explain the trouble the next step is a thorough visual inspection.

B. Visual Inspection

A good visual inspection may often save hours of tedious troubleshooting. Make a habit of proceeding in an orderly manner to insure that no vital part of the

following procedure is omitted. The visual inspection can be performed in 10 to 15 minutes. It is recommended both as a preventive maintenance procedure and also for its value in determining cause of malfunction.

- 1) Check that all external screws are tight and that none are missing.
- 2) Check all fuses/circuit breakers.
- 3) Check for smooth and proper operation of switches, etc.
- 4) Inspect line cord for possible damage to cap, jacket and conductors.
- 5) Remove protective covers as outlined in disassembly instruction (Section 7.5).
- 6) Check that all attaching parts for internal circuits are tight and that none are missing.
- 7) Inspect all wiring for charred insulation, or discoloration as evidence of previous overheating.
- 8) Check that all electrical connections are secure. This includes wire terminals, screw and stud type terminals, and all soldered connections.
- 9) Check for obvious destruction of internal structural parts. Distortion in any of these parts could mean that the unit has been dropped or subjected to severe shock.

7.5 Disassembly for Inspection, Service, Testing, Adjustment and Repair

The extent of disassembly required will depend upon the extent of inspection, service, testing, adjustment and repair to be performed. Illustrations referred to in parenthesis are located in the parts list (Section 6) of this manual.

A. Cover Removal

A fairly complete visual inspection can be performed by removing the top (92) and bottom (93) covers. To remove these parts, proceed as follows:

1. Remove the eleven phillips head mounting screws (94) that secure the top cover. Gently lift cover and remove.
2. Remove the eleven phillips head mounting screws (94) that secure the bottom cover. As with the top cover, the bottom cover can now easily be removed.

B. Main Board Removal

The PL-1 has been specially designed for ease of service. Every component part is easily accessible (with the covers removed) for fast and effective replacement. This means it should never be necessary to replace the Main Board unless damage was done beyond repair (severed, burnt, etc.) to the board itself. (Most cases of main board destruction will also require output transistor replacement as well as drivers.) If this occurs, proceed as follows:

1. Refer to the component board layout, Fig. 6.3.

2. Disconnect all cables and wires which connect to/from the board at solder points ("P-1", etc.) indicated on board layout Fig. 6.3. Note their location for future reconnection.
3. Disconnect all wires attached to the Power and Monitor pushbutton terminal strips. Note their location for future reconnection.
4. Remove front panel knobs (41) and associated hardware. Also remove headphone jack mounting knurled nut(61).
5. Remove the four (two each side) phillips head handle mounting screws (48). This will free the black handles, black front panel, power LED, and will also expose the aluminum frame.
6. The LED display cover (60) should be removed next by simply lifting it out of its mounting space.
7. To remove the aluminum front panel with the main board still attached, it will be necessary to remove the predriver mounting hardware (62,63) from the back (rear) side of the main board. It will then be necessary to raise each predriver transistor to its upright position in order to ease removal.
8. Unsolder each output transistor mounting terminal (72) from the foil side of the Main Board.
9. Aluminum front panel and Main Board should now be free to come forward and out. Replace the Main board by removing two Monitor pushbutton mounting screws (55,56) and disconnecting the display board wire connections. Note their location for future hook-up.
10. Reassembly is the reverse of above.

C. Display Board Removal

1. Refer to the component board layout (Fig. 6.3) and note all wires which connect to the Display Board.
2. Unsolder the six Display board connect wires at the Main Board.
3. Remove the four phillips head, board mount screws (53) located at each corner of the Display Board.
4. Slide the board upward and out to remove.
5. Replacement is reverse of above.

D. Front Panel Parts Replacement

All component parts located near or on the front panel can be replaced by removing all related mounting hardware and unsoldering the part from the foil side of the Main Board.

In order to change any component parts from the Display Board, it will be necessary to remove the board from the front panel (see Display Board removal).

1. Input Level Control removal is accomplished by first removing the front panel knobs(41). Simply pull straight out with fingers placed firmly around the outside of the knob. Next, remove mounting nut and ring washer (42,43) from the front panel. The

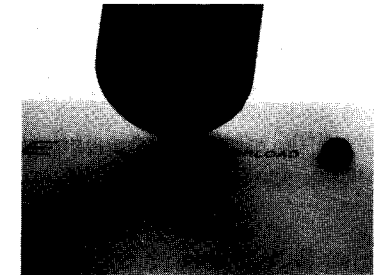

Fig. 7.18 LED Removal

only remaining restraint is the terminal mounting strips which must be unsoldered from beneath. After this point, the potentiometer can be lifted out easily.

2. On/Off switch replacement: To replace the front panel on/off switch (59) unsolder all related wiring at the switch. With a small "offset or S shaped" screwdriver remove two mounting screws (Fig. 7.17). Switch may now be replaced.

strike the socket-end of the nut driver with a small ball peen hammer. To replace, apply one drop of Eastman 910 cyanacrolete or Loctite Super Bonder to the edge of the substitute LED (Fig.7.19) during reinsertion. Apply a small amount of pressure from the back side until the glue has set (about 10 seconds). **Note:** Be careful not to use excessive amount of glue. Reconnect supply wires making sure polarity is correct. If in doubt, observe the small flat edge, located to one side of the lead-in wires on the LED (Fig. 7.20). The flat side is the cathode or the "solid orange wire" side.

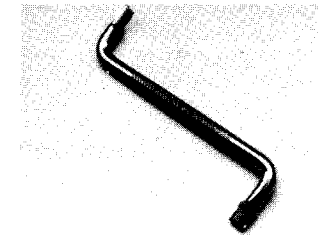

Fig. 7.17 Offset Screwdriver

3. Headphone jack replacement is done by removing the front panel knurled nut (61) and all related wiring at the jack itself.
4. Monitor Switch removal is accomplished in basically the same manner as on/off switch removal. However, in this case it will be necessary to unsolder the bottom mount terminal strip as well as removing the small phillips head mounting screws (56).
5. LED "On-Off" Indicator Replacement: This procedure is not likely to be necessary because of the high reliability factor of the indicator LED used. However, should an occasion arise for such a procedure, remove the front panel (45) by extracting the four phillips head handle mounting screws (48), and removing the input level control and headphone jack hardware. Disconnect the wire connected to the rear of the LED by gently pulling the connectors away from the front panel. With the "handle-end" of a 1/4" nut driver, apply pressure to the LED from the front panel side (Fig.7.18). It may be necessary to gently

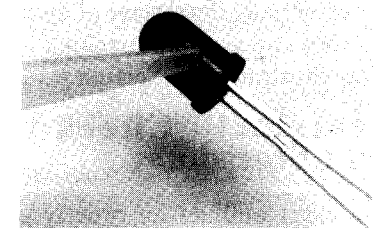

Fig. 7.19 Cyanacrolete Application

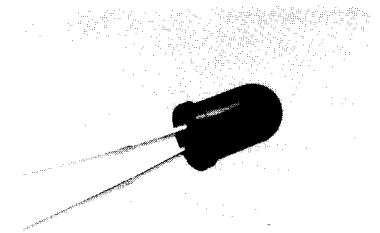

Fig. 7.20 Cathode Lead of LED

E. Output Transistor Replacement

- Each of the four Output transistors (Q103, Q203, Q112, Q212) can be replaced easily by using a small shaft phillips screw driver to remove the output mount screws (69). This can be done most effectively by utilizing back panel access holes. At this point, a small amount of lifting pressure underneath the output transistor will allow it to come free.
- Replacement is reverse of above.

F. Power Supply Parts Replacement

All component parts located in this area can be replaced with relatively little effort. All mounting hardware is easily accessible making repair basically straight-forward.

G. Back Panel Parts Replacement

Parts located on the PL-1 rear panel (1) for the most part can be removed by unscrewing the mounting hardware from the outside. The only exceptions to this statement are the fuse holder (9) and the MDP Banana jacks (7). To remove these, it is necessary to work from the inside of the unit.

Note: It is possible to loosen the rear panel (1) by removing the two phillips head mounting screws (3) located on the rear sides. This may aid in hardware access.

7.6 Reassembly

Reassembly is essentially the reverse of disassembly. If in doubt about types and sizes of attaching parts, refer to the appropriate illustration in Section 6.

7.7 Electrical Checkout and Adjustment Procedures

The following chart outlines an orderly checkout and adjustment procedure for the PL-1. The test equipment required to perform the various procedures is listed in Section 7.2.

Checkout and Adjustment

Type of Test/Adjustment	Input Signal Characteristics	Comments
1. Quiescent DC Offset	None	DC millivolt meter connected to the output of each channel. Input level control is varied throughout its range while observing $\pm 10\text{mV}$ readings.
2. Bias Adjustment	None	Positive output, base emitter junction should be between .3V and .35V. It is altered by selected resistors R126 and R226 (typical value between 92 and 240 ohms).

Type of Test/Adjustment	Input Signal Characteristics	Comments
3. Power (One channel driven)	1 volt; 1KHz sine wave	Into 8 ohms, 21.9 VRMS (60W) should be obtainable before signal clip. Into 4 ohms, 17.8VRMS (50W) should be obtainable before signal clip.
4. Protection Circuit	1 volt; 1KHz sine wave	Without a load, at least 21.9 VRMS should be obtainable before signal clip. Into 2 ohms, the output will appear as in Fig. 7.21.

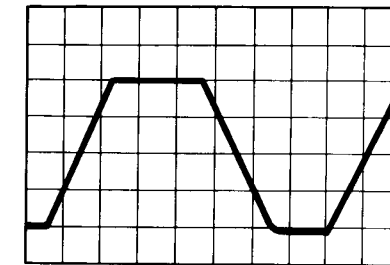

Fig. 7.21 PL-1 Output Waveform (2 ohm)

5. High Frequency	1 volt; 10KHz square wave 1 volt; 20KHz square wave	Into an 8 ohm load, a 30 volt peak-peak square wave signal should exhibit no ringing. Into an 8 ohm load, a 20VRMS square wave signal should exhibit no ringing.
6. Intermodulation Distortion (8 ohm load)	.5V $\pm 2\%$ 60Hz/7KHz signal summed in 4:1 ratio	Due to the extremely low amounts of IM Distortion in the PL-1, test equipment residual will be the lowest possible reading. If this reading is taken it should be done as shown in test hook-up diagram Fig. 7.22.
7. IOC	30V peak-peak .5Hz square wave	IOC light should illuminate once for every rise time and once for every fall time (twice every full cycle).
8. Turn-on Mute	1 volt, 1KHz sine wave	Check for seven second delay upon turn-on at switched output.
9. Overload/DC Protection	Variable, 1KHz sine wave	Apply an input signal capable of illuminating the IOC indicators. After seven seconds, the switched output signal should be removed.
10. LED Ladder Adjustment	Variable, 1KHz sine wave	Vary input signal so that -.1VDC appears at test point 1A/1B. Adjust R157/257 for 0VDC at test point 2A/2B. With 20VRMS at the amplifier output jacks, vary R132/232 for maximum brilliance of the top yellow LED.
11. Signal to Noise	--	See Fig. 7.23. Signal to noise should be 106dB below rated output.
12. Quiescent AC Power	None	25 watts at idle as monitored by wattmeter in AC line; 275 watts at full rated output.

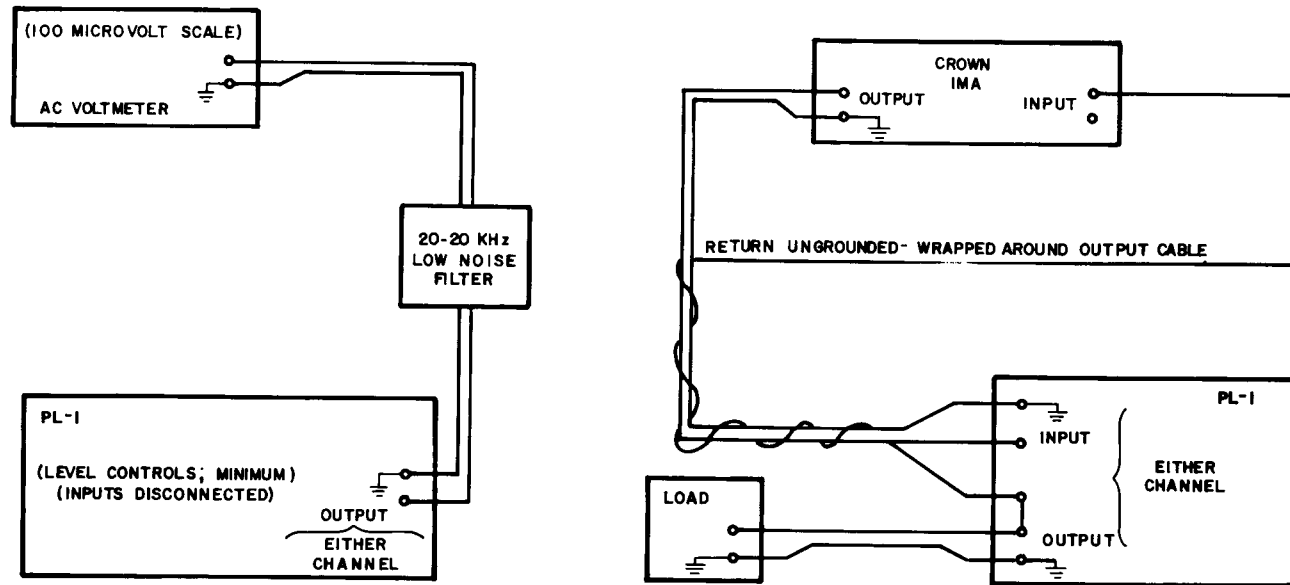

Fig. 7.22 IM Distortion Test Set-up

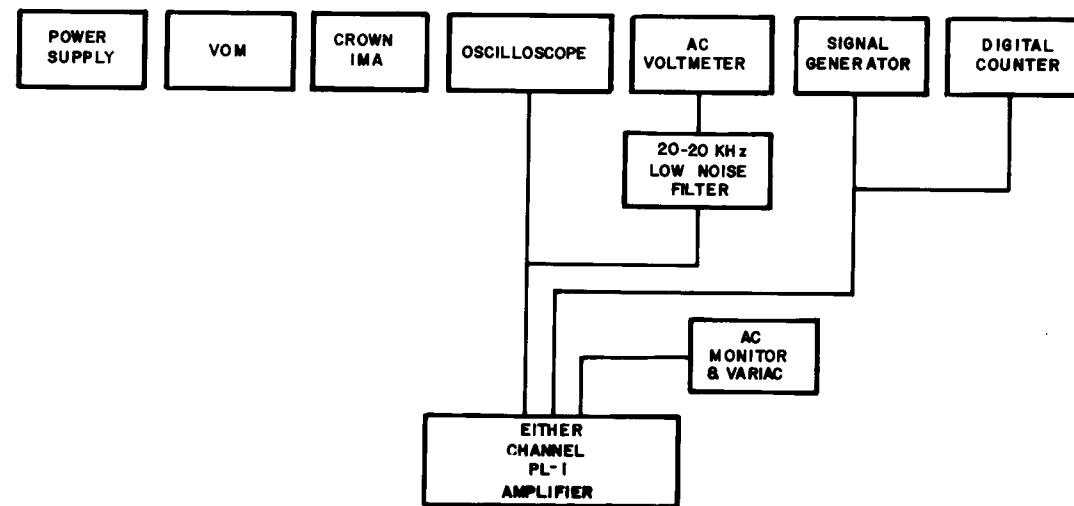

Fig. 7.23 Signal to Noise Test Set-up

7.8 Troubleshooting Chart

Symptom	Possible Defect
High IM Distortion Load Related (occurs only when amplifier is connected to loads)	<ol style="list-style-type: none"> 1. Defective IC op amp (IC3A,B) 2. C123, C201 open 3. R114, R214 open or not soldered properly 4. C106, C206 open (amplifier will exhibit high IM, DC offset drift and noise) 5. C121, C221 open 6. Q113, Q213 open, leaky or shorted
Low dB IM Distortion	<ol style="list-style-type: none"> 1. Low output transistor bias 2. High signal to noise (see below) 3. C118, C118, C120, C220 open
High IM Distortion, Not Load Related (occurs regardless of load connection)	<ol style="list-style-type: none"> 1. R125, R225 value change 2. R161, R261 value change 3. C118, C218, C120, C220 value change
High Signal to Noise	<ol style="list-style-type: none"> 1. Loss of input ground isolation from chassis 2. D103, D216 zener diode defective 3. Broken ground on input jack, input cable or on input level control 4. Amplifier instability (oscillation - C106, C206 defective)
Protection Circuit Problem -No current limiting	<ol style="list-style-type: none"> 1. Current limiting transistor open <ol style="list-style-type: none"> a. positive (Q105, Q205) b. negative (Q107, Q207) 2. D102, D202, D108, D208 open 3. C110, C210, C107, C207 shorted 4. R119, R219, R111, R211 open
-Excessive limiting	<ol style="list-style-type: none"> 1. Q107, Q207, Q105, Q205 shorted 2. D108, D208, D102, D202 shorted 3. Loose output transistor hardware
-Current limiting oscillation	<ol style="list-style-type: none"> 1. Negative feedback components in limiting transistor circuit defective; C103, C203, C117, R217, R106, R206, R120, C220
Clipping (positive) Single Channel	<ol style="list-style-type: none"> 1. Open or leaky predriver; Q101, Q201 2. Shorted or leaky limiting transistor Q105, Q205 3. L101, L201 open 4. R113, R213 value change 5. Defective IC op amp (IC3A,B)
Clipping (negative) Single Channel	<ol style="list-style-type: none"> 1. Open or leaky predriver; Q109, Q209 2. Shorted or leaky limiting transistor Q107, 207 3. L102, L202 open 3. R115, R215 value change

Symptom	Possible Defect
120Hz in output Waveform	<ol style="list-style-type: none"> 1. Power supply filter capacitors open 2. Power supply filter capacitor mounting hardware loose
Positive Half of Signal Missing	<ol style="list-style-type: none"> 1. R 100, R200 open 2. Loss of positive supply voltage 3. Q104, Q204 open 4. Positive predriver open; Q101, Q201 5. R113, R213 open
Oscillation (Full Waveform)	<ol style="list-style-type: none"> 1. R 114, R214 open 2. C109, C209 open 3. C114, C214 open
Oscillation (Positive Half)	<ol style="list-style-type: none"> 1. Defective positive predriver or driver Q101, Q201 Q102, Q202 2. C102, C202 open 3. C107, C207 open 4. C111, C211 open
Oscillation (Negative Half)	<ol style="list-style-type: none"> 1. C116, C216 open 2. Defective negative predriver or driver; Q109, Q209, Q110, Q210
Clipping (positive) Both Channels	<ol style="list-style-type: none"> 1. D103 leaky 2. Defective IC op amp (IC3A,B)
Positive DC Offset -Single Channel-	<ol style="list-style-type: none"> 1. Defective IC op amp (IC3A,B) 2. Q106, Q206 open 3. Q113, Q213 open, leaky or shorted 4. Q111, Q211 open, leaky or shorted 5. Positive predriver, driver or output device leaky or shorted Q101, Q201, Q102, Q202, Q103, Q203 6. Bias transistor shorted; Q108, Q208
Negative DC Offset -Single Channel-	<ol style="list-style-type: none"> 1. Defective IC op amp (IC3A,B) 2. Mono switch hot wire shorted to ground (SW1) 3. Negative predriver, driver or output device leaky or shorted Q109, Q209, Q110, Q210, Q112, Q212 4. Q106, Q206 Base collector leakage
Small DC Offsets	<ol style="list-style-type: none"> 1. Broken ground on input level control 2. Input jack hot lead and ground pin not shorted together (level controls full up with no input jack) 3. D104, D204 defective
Negative Half of Signal Missing	<ol style="list-style-type: none"> 1. Q109, Q209 open 2. Negative power supply problem (main board)
Blows Fuses	<ol style="list-style-type: none"> 1. Rectifier block shorted 2. Leaky or shorted filter capacitor 3. Shorted transformer 4. Pinched wires in power supply 5. Leaky or shorted output transistors 6. Shorted bias transistors Q108, Q208

Symptom

Possible Defect

No Output stage bias

1. No bias resistor; R126, R216
2. Bias resistor terminal lug not soldered properly to circuit board
3. L100, L200, L102, L202 open
4. C-E short of bias transistor Q108, Q208

High Bias voltage (Amplifier heats up)

1. Amplifier instability-high frequency oscillation (check Q113, Q213)
2. Shorted output terminal post
3. DC offset (see offset section)

Negative DC Offset
-Both Channels-

1. Defective IC op amp (IC3A,B)
2. Q406, Q206 shorted
3. D103 shorted

Positive DC Offset
-Both Channels-
Burned B-E Resistors
on Output Transistors

1. Defective IC op amp (IC3A,B)
2. D216 shorted
1. Open output transistor socket.

7.9 Principles of Operation

The dual IC op amp is of low noise type having a large gain bandwidth. The result of using it for the input voltage amplifier is that a maximum amount of feedback is applied, reducing distortion to extremely low values. Multiple feedback loops are also employed to allow a maximum of overall feedback.

The lack of noise is evidenced by a typical 20Hz-20KHz effective input noise of 1.25 microvolts, which produces into an 8 ohm load an output of 80 micromicro watts (80 pico watts).

The output stage is a quasi-complimentary format employing the Crown class AB+B technique which uses no bias current in the output transistors. The result is maximum efficiency with minimum crossover notch distortion and minimum amplifier heat at idle. Thus there is no bias current adjustment, and the output circuit is not temperature-tolerance critical.

In the output circuit, the driver transistors carry the bias current, while the output transistors serve only as boosters. The output transistors sense when the driver transistors are delivering significant current to the load and take over to deliver the large load currents.

The output circuit is protected by a V-I limiter which limits the drive to the output configuration whenever the output transistors are overloaded. V-I (volt-ampere) limiting is inherently superior to all previous forms of protection as it directly senses the overload condition and acts instantly to relieve the overload, acting only so long as the overload exists. The result is complete freedom from program delays with reliability and maximum safe output power.

The power supply is a continuous-duty type. The main DC supplies are full-wave capacitor input type with a heavy duty bridge rectifier assembly and computer grade electrolytics.

7.10 Block Diagram Circuit Theory

The unbalanced input signal is fed from the RCA-type pin jack through a 25K ohm potentiometer (the GAIN control) to the IC input buffer amplifier. This signal is then fed to a stage of power amplification where it is boosted to a level of sufficient amplitude to drive an OUTPUT LOAD.

The IOC (Input Output Comparator) circuitry works in conjunction with the error correcting signal of the main op amp. Any time a small "non-linearity" exists in the amplifier, an error signal appears at the output of the main op amp (via the feedback loop of the unit). This produces an abnormally high value, exceeding the "window" of the IOC and illuminating the LED. Since transient overload can happen rapidly, a pulse stretching circuit is added so the eye can detect the LED lighting.

A sample of the OUTPUT signal is fed to the OUTPUT LEVEL circuitry. The higher the voltage level, the more LED's are illuminated in the channel's OUTPUT LEVEL display.

The POWER SUPPLY exists to supply the proper voltages to the various circuit components within the amplifier. A bipolar 42 volt supply provides the power for the output stages.

In the mono mode, the stereo-mode switch applies the output of the CH 1 amplifier to the inverting, unity gain input of CH 2. Channel 2 output will then be equal in amplitude to Channel 1 but opposite in polarity. With the outputs "swinging" in opposite directions, and a load connected across the hot terminals (+) of the two channels will "see" twice the voltage that would be obtained across the (+) and (-) terminals of either channel's output.

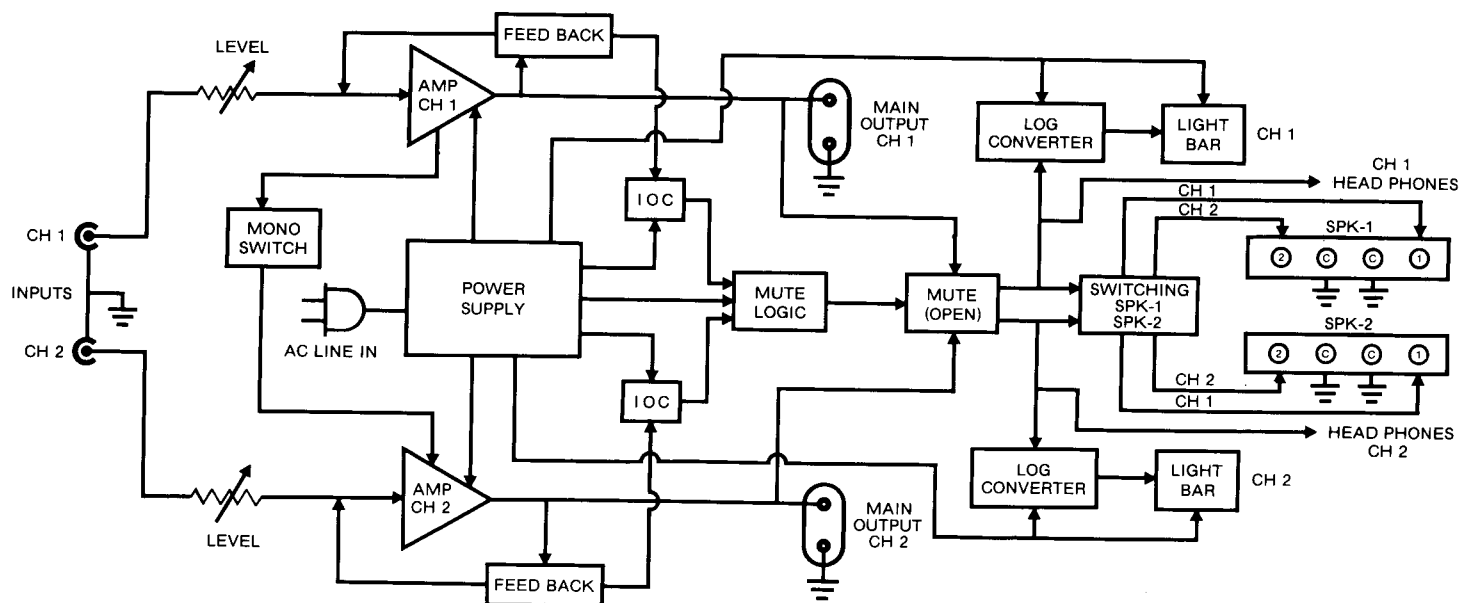

Fig. 7.24 PL-1 Block Diagram

7.11 Theory of Operation

The following explanation refers to schematic diagram MI-273A and MI-274A located in the Instruction Manual as well as at the beginning of this manual. However, each circuit under discussion is reprinted below in order to aid in circuit familiarization. Only channel 1 is shown for simplicity.

A. Input Operational Amplifier

After entering via back panel pin jacks (J100, J200), the input signal travels to the Input Operational Amplifier. IC3A is a low noise, large gain bandwidth integrated circuit. Under its formal name, UA739, it acts as an input voltage amplifier producing extremely low distortion by means of several feedback paths. The gain determining components for the overall amplifier are two voltage dividing resistors, R125 and R161. Note that they act as a feedback path from the output of the main amplifier to the inverting input of IC3A (pin 6). Both signals entering IC3A at pins 5 and 6 will be in phase with each other because of this feedback path and will thus produce an output (pin 1) of almost zero. The IC op amp will always try to keep a zero potential difference between both inputs. The small amount of output signal that is present is there because of the finite gain of the amplifier.

Any type of non-linearity will cause the op amp to produce a large output, and therefore a substantial size correction signal in order to retain the small input level.

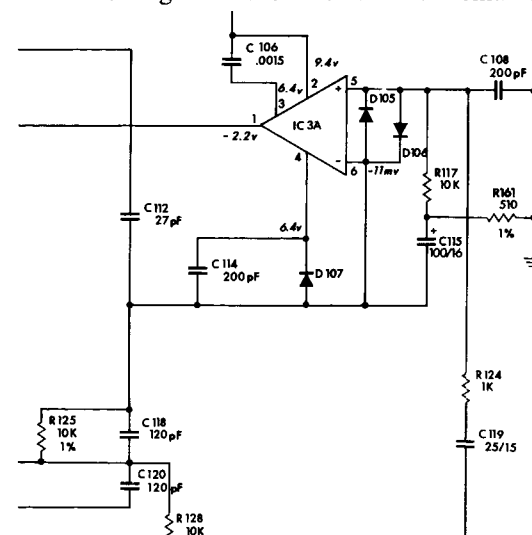

Fig. 7.25 Input Operational Amplifier Stage



B. Signal Translator

The operation of the PL-1 front-end circuitry (IC op amp through Q111) is to basically provide voltage amplification. However, the signal translator transistor (Q106) provides no voltage amplification itself, but rather converts the ground referenced input signal to a signal with a reference to the negative supply. The result is higher voltage swing capabilities from Q111 (Final Voltage Amplifier).

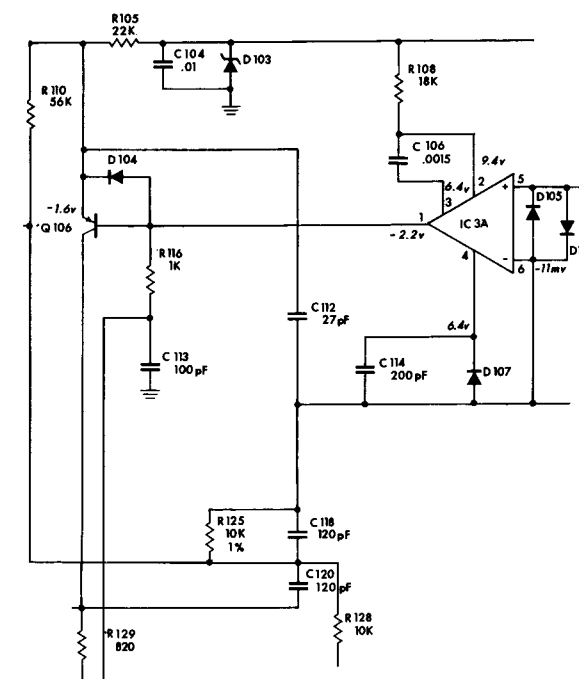

Fig. 7.26 Signal Translator Stage

C. Final Voltage Amplifier

The Final Voltage Amplifier transistor (Q111) is the main voltage amplification stage. All signal voltage that appears at the output is developed here. R129 connected to the base circuit of Q111 serves two purposes:

- 1) it provides collector current for Q106
- 2) provides a current which is available to charge C120.

As the collector current of Q106 varies at the frequency and amplitude of the incoming signal, this same variation is placed across the Final Voltage Amplifier transistor base bias resistor and is impressed upon the base of Q111.

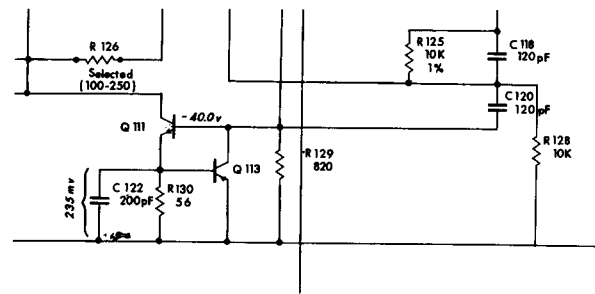

Fig. 7.27 Final Voltage Amplifier Stage

D. Bias

Basically, the output of the Final Voltage Amplifier provides the signal drive to the predrivers (Q101, Q109), drivers (Q102, Q110) and output transistors (Q103, Q112) in order to amplify the current for final output power. The correct bias supply (bias transistor Q108) voltage of 2.1V DC is distributed throughout the current amplification stages in the following manner:

- a) Base to Emitter junction of Q101 positive predriver is .6V
- b) Base to Emitter junction of Q102 positive driver is .6V (negative driver Q110 and output transistor Q112 have fixed base emitter bias)
- c) Base to Emitter junction of Q103, positive output transistor is biased to sub turn-on state.

As the amplifier under loaded operating conditions increases in temperature, the bias sensing transistor (Q108) temperature increases proportionally. This condition reduces the base to emitter bias voltage produced by the bias supply which results in prevention of thermal runaway.

E. Output Stage

There are several categories or classes in which amplifiers are placed, the most common being class A, B or C. Each class or combination thereof, has a specific amount of bias current applied to the transistor which determines its operating conditions. A class A amplifier, will be biased such that a transistor operates always in the active region (360°) between saturation and cutoff. A class B amplifier is biased at cutoff (180°) and Class C below cutoff. The PL-1 output stage is designed in Class AB+B mode of operation where the driver transistors (Q102, Q110) carry the bias current while the output transistors (Q103, Q112) serve only as boosters. The output transistors sense when the driver transistors are developing significant current draw from the load and thus take over and deliver the needed current.

The output stage is of a quasi-complementary format using no bias current into the output transistors themselves. The result is maximum efficiency with minimum crossover notch distortion and idling amplifier

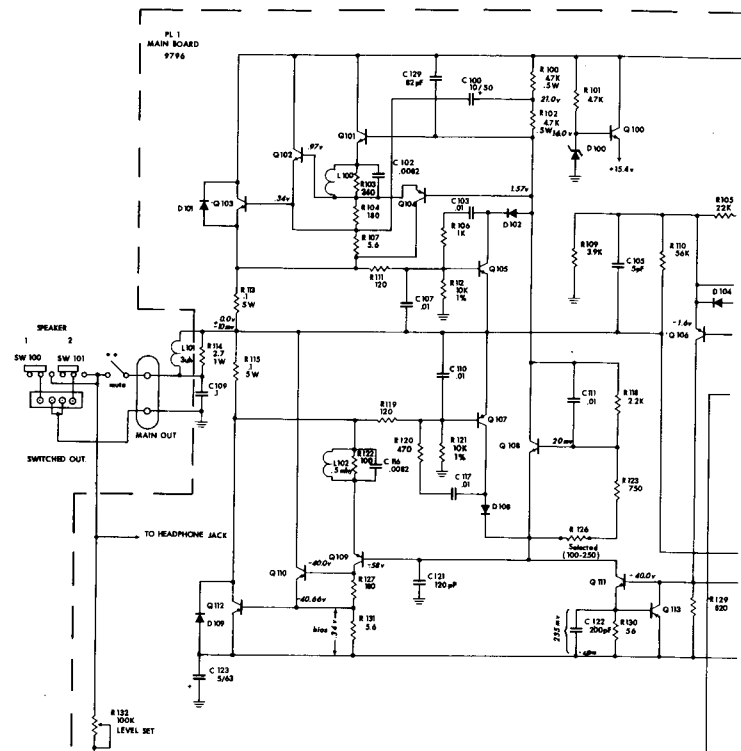

Fig. 7.28 Bias Output and Protection Stages

heat. Also, note that there is no bias current adjustment, as the output stage is not temperature-tolerance critical.

F. Protection Circuitry

The PL-1 utilizes Voltage-Current limiting for protecting the output stages. V-I limiting is superior to most other forms of protection because it directly senses the overload condition and instantly reacts to relieve the overload, and acts only as long as the overload exists.

Should the output current become dangerously high, the voltage induced in the current limiting sense resistors (R113, R115) is fed to the limiting transistors (Q107, Q105). The protection circuitry will then "clamp" a limit on the signal whenever it threatens to push the output stage beyond its capabilities. The limit point is determined by a combination of the predriver plus limiter current equaling the available current source on the main board. In other words, the signal drive that is fed to the predrivers is limited or clamped.

G. IOC

The front-panel IOC display is actually a window comparator circuit using two operational amplifiers (IC1A,B) and an LED indicator (LED 100).

Any small nonlinearity in the amplifier causes an error in the feedback loop to appear at the inverted input of the main IC op amp (IC3A). This means the main IC output (pin 1) will rise above its normal value in an attempt to correct the problem. When this signal exceeds the bias voltage on IC1 it inturn activates Q114 which illuminates LED 100. R147, C127 with Q114 and Q115 form a pulse stretcher circuit to hold the LED on for .75 seconds so it can be seen, even if the nonlinearity exists for only a few microseconds

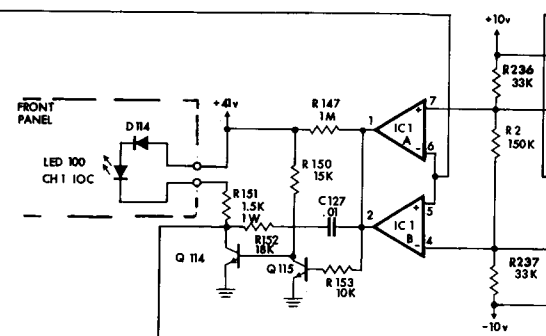
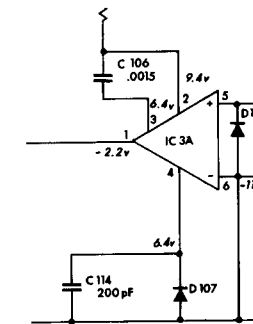

Fig. 7.29 IOC Indicator Stage

H. Ladder Display Circuitry

The PL-1 Ladder Display circuitry consists mainly of IC101, IC102 and their related component parts. As the signal is taken directly from the output circuitry, it is fed to IC101A and B which together, act as a full wave detector.

IC101A is an inverting amplifier. During positive "main amplifier" signals, D112 connects the negative output of IC101A to the feedback resistor (R143) and also to the non-inverting input of IC101B. The gain of IC101A is determined by R132, R140 and R143 (R141 is at zero voltage). With this condition, IC101B is a unity gain, non-inverting amp with a negative output. With negative "main amplifier" signals, D113 connects the positive output of IC101A to its feedback resistor (R141) and also to the inverting input of IC101B. The gain of IC101A is now determined by R132, R140 and R141 (R143 is at zero voltage). Under these conditions, IC101B will act as a unity gain, inverting amp with a negative output. The peaks produced at its output IC101B are the determining factors in the amount of voltage charge that will be stored at C125 and later used as a reference for the amount of rise illumination in the ladder display. IC101C and D and related component parts create a log convertor. This circuit will take the log value of the incoming signal peak and transmit it (via voltage divider R154, R155 and R158) to IC102. The result is a linear driven ladder display (IC102, LED stick 100, 101) showing an accurate output step level proportional to dB.

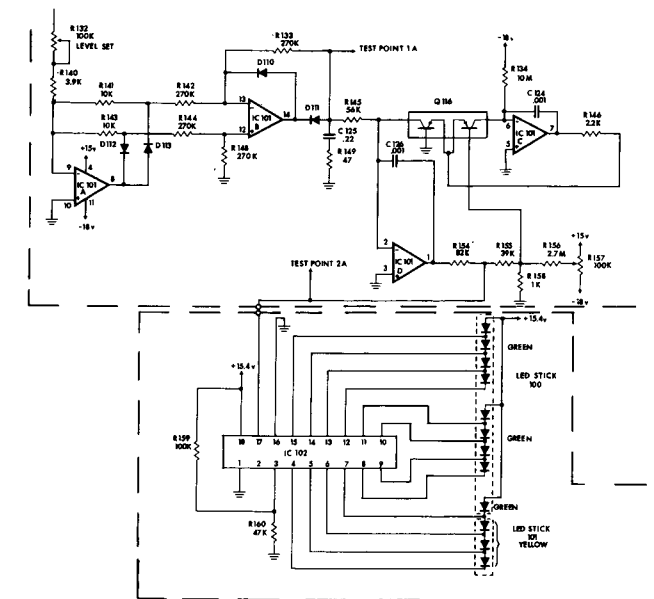

Fig. 7.30 Display Stage

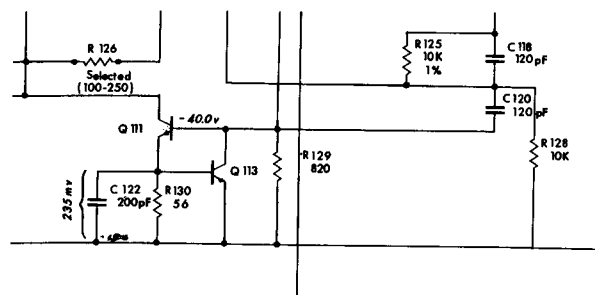

Fig. 7.27 Final Voltage Amplifier Stage

D. Bias

Basically, the output of the Final Voltage Amplifier provides the signal drive to the predrivers (Q101, Q109), drivers (Q102, Q110) and output transistors (Q103, Q112) in order to amplify the current for final output power. The correct bias supply (bias transistor Q108) voltage of 2.1V DC is distributed throughout the current amplification stages in the following manner:

- a) Base to Emitter junction of Q101 positive predriver is .6V
- b) Base to Emitter junction of Q102 positive driver is .6V (negative driver Q110 and output transistor Q112 have fixed base emitter bias)
- c) Base to Emitter junction of Q103, positive output transistor is biased to sub turn-on state.

As the amplifier under loaded operating conditions increases in temperature, the bias sensing transistor (Q108) temperature increases proportionally. This condition reduces the base to emitter bias voltage produced by the bias supply which results in prevention of thermal runaway.

E. Output Stage

There are several categories or classes in which amplifiers are placed, the most common being class A, B or C. Each class or combination thereof, has a specific amount of bias current applied to the transistor which determines its operating conditions. A class A amplifier, will be biased such that a transistor operates always in the active region (360°) between saturation and cutoff. A class B amplifier is biased at cutoff (180°) and Class C below cutoff. The PL-1 output stage is designed in Class AB+B mode of operation where the driver transistors (Q102, Q110) carry the bias current while the output transistors (Q103, Q112) serve only as boosters. The output transistors sense when the driver transistors are developing significant current draw from the load and thus take over and deliver the needed current.

The output stage is of a quasi-complementary format using no bias current into the output transistors themselves. The result is maximum efficiency with minimum crossover notch distortion and idling amplifier

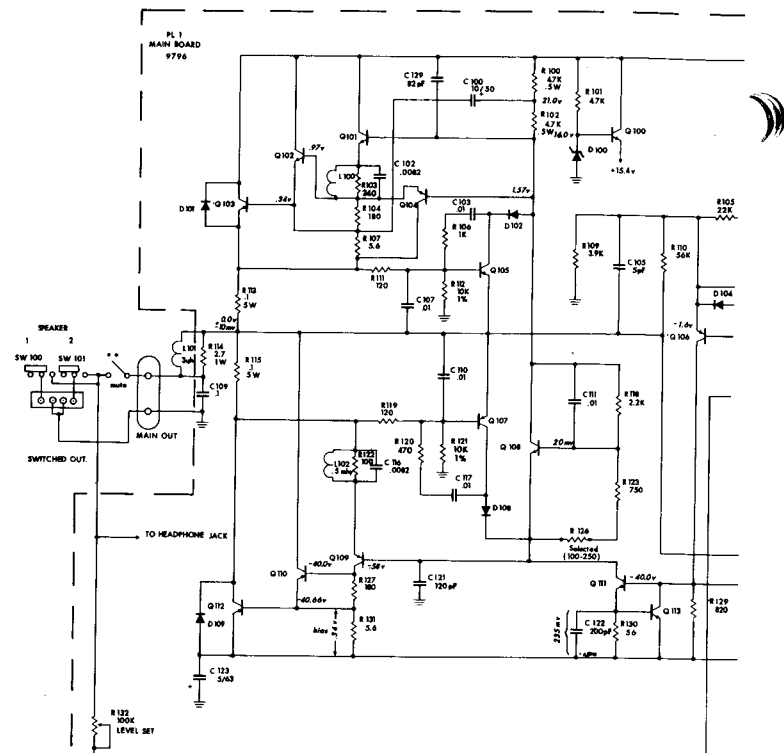

I. Low Frequency Protect/Mute Circuitry

On initial turn on, the PL-1 will (when speakers are connected to switched outputs) provide a seven second delay to help eliminate annoying pops/thumps. This is achieved through the logic circuitry of IC2 along with capacitors C1 and C2, resistors R6 and R7 and diodes D1 and D2. As a charge is developed across C2, a point is reached where IC2C will go high at pin 2. This means its output is now low (definition of nand gate; pin 1 is also high) as it is fed into inverter IC2D. Through the inverter, the output is once again high, activating Q1 and likewise the relay.

Note that relay K1 is normally open and therefore must be activated in order to obtain a signal at the output.

Another feature of this circuitry is that it will also detect any faults (excessive DC output failure, etc.) in the amplifier system and will automatically disconnect output to the speakers. This feature monitors the IOC circuitry as shown through connections at Q114 and R4. Voltage on the collector of Q114 is high when the IOC circuitry is not active. This retains the closed position of K1 and thus the output signal is not interrupted. However, should the IOC circuit activate, Q114 collector voltage will go low. At that point, IC2A will produce a high output, allowing C3 to slowly (about 5 seconds) build up a charge high enough to overcome the switching threshold of IC2B. When this is achieved, the output of IC2B will be low, producing a discrepancy at the input of IC2C. This means the output of IC2C will be high producing low output at inverter IC2D, turning Q1 off as well as K1.

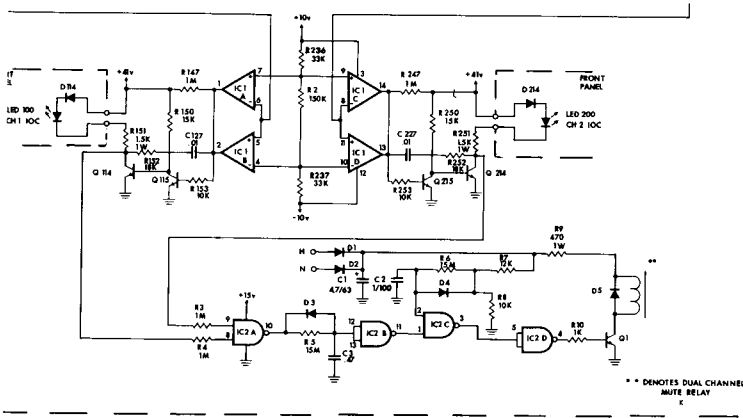

Fig. 7.31 Low Frequency Protect/Mute Stage

7.12 Voltage Conversion

Often Crown products are purchased in one country and later moved to another requiring an AC mains conversion. For this reason the following chart/explanation as well as a world-wide voltage map is provided.

The PL-1 power supply may be connected for any of five voltages. Converting from one to another can be accomplished with a soldering iron and a pair of wire cutters. Follow the table shown with the schematic, and the drawing below.

1. Remove the top cover of the PL-1 (held on by 11 screws).
2. With the unit right side up, and the front panel toward you, locate the terminal strip in the rear left-hand corner.
3. Make the appropriate change in jumpers for the desired operating voltage. See Fig. 7.32.
4. Replace the 3 amp line fuse with a 1.5 amp type 3AG fuse, for all connections 200V and above.
5. Change the line cord tag to read the correct voltage.

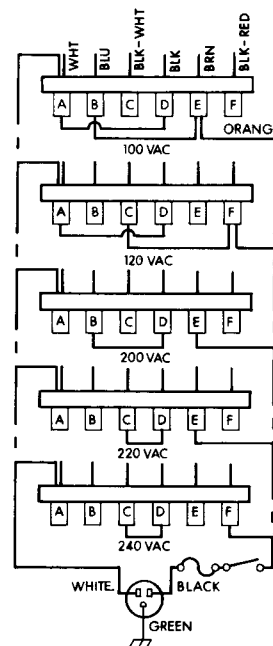

Fig. 7.32 Voltage Conversion